

Double-wall, Flat Oval Duct and Fittings Dimensions

McGill AirFlow Corporation has a complete line of double-wall, insulated, flat oval duct and fittings. Each piece is constructed of an inner liner (either perforated or solid metal) surrounded by a layer of insulation and covered by a solid metal pressure shell. The insulation, which serves both thermal and acoustical purposes, comes in 1-, 2-, and 3-inch thicknesses and a maximum 1.5 pcf density¹ to meet the thermal and acoustical performance requirements found in most HVAC systems.

Table 1 - Double-Wall, Flat Oval Duct - Available Materials and Thicknesses²

Construction	Lengths ³	Materials ⁴	Thicknesses
ACOUSTI-k27[®] Duct (spiral lockseam)	1-12 feet	Galvanized Steel	26-18 gauge
		Stainless Steel	26-20 gauge
		Aluminum	0.025-0.063 inch ⁵
Longitudinal Seam-k27[®] Duct (solid welded)	1-6 feet	Galvanized Steel	20-10 gauge
		Stainless Steel	22-10 gauge
		Aluminum	0.040-0.090 inch ⁵

Table 2 - Double-Wall, Flat Oval Fittings- Available Materials and Thicknesses²

Construction	Materials ⁴	Thicknesses
ACOUSTI-k27 Fittings ⁶ (spot welded and bonded, or standing seam)	Galvanized Steel	26-10 gauge
	Stainless Steel	26-10 gauge
	Aluminum	0.032-0.090 inch ⁵

1. Standard insulation density is 1.0 pcf.

2. Standard McGill AirFlow double-wall, flat oval duct and fittings are available in the dimensions shown in Table 4.

3. Some standard lengths of ACOUSTI-k27 flat oval duct are only available in 6-foot lengths; longer lengths are available on special order. Standard lengths of Longitudinal Seam-k27 duct are 5 and 6 feet.

4. Double-wall, flat oval duct and fittings are also available in carbon steel, paintable galvanized steel, and aluminized steel.

5. Aluminum double-wall, flat oval duct and fittings are available in larger sizes and greater metal thicknesses on special order.

6. Fittings 16 gauge (Aluminum - 0.090 inch) or heavier are fully welded.

7. See Table 3 for a full range of available spiral flat oval sizes by gauge.

Duct Construction

Spiral Lockseam

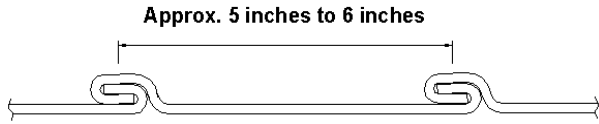

Longitudinal Seam

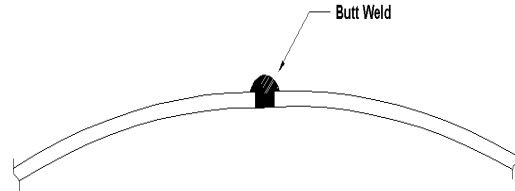

Table 3 - Available Range of Spiral Duct Basic Round Diameters Used to Fabricate Spiral Flat Oval Duct Outer Shells by Thickness¹

Gauge	Galvanized Steel, Aluminized Steel and Nongalvanized Carbon Steel	Stainless Steel (304, 304L, 316 and 316L)	Aluminum ²	
	Spiral Lockseam Basic Round Outer Diameter (inches)	Spiral Lockseam Basic Round Outer Diameter (inches)	Thickness (inches)	Spiral Lockseam Basic Round Outer Diameter (inches)
28	8 - 14 1/2	N/A	0.040	8 - 60
26	8 - 26	N/A	0.050	8 - 60
24	8 - 36	8 - 50	0.063	8 - 60
22	8 - 50	8 - 60		
20	8 - 60	8 - 64		
18	8 - 64	N/A		

¹ Thicker material may be available in some basic round diameter ranges; check with your local sales office.

² Aluminum double-wall, round, spiral duct is available in larger basic round diameters on special order.

Solid Welded

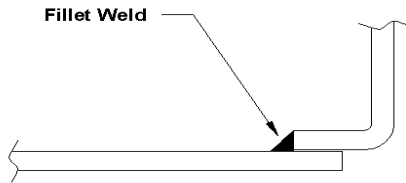

Spot Welded, Tack Welded or Mechanical Fastened

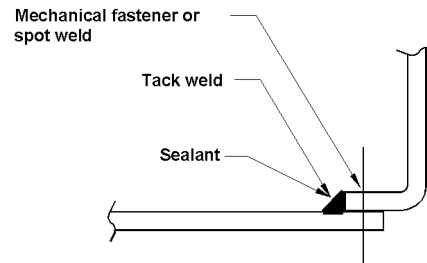

Sealed with United Duct Sealer™ (Water Based)

Standing Seam

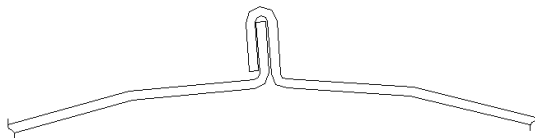

Sealed with United Duct Sealer (Water Based) or UNI-WELD weld sealant

Resistance Seam Welded

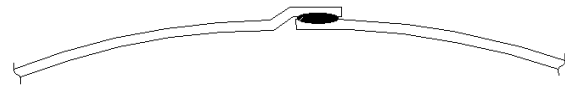

Sealed with United Duct Sealer (Water Based)

Dimensioning

(All alphanumeric dimensions are in inches, all angles are in degrees)

A	-	Main barrel inlet major axis
a	-	Main barrel inlet minor axis
B	-	Main barrel outlet major axis
b	-	Main barrel outlet minor axis
C or D	-	Branch tap major axis (Note: On tee and lateral fittings with two taps, C is the branch closest to the inlet of the fitting. On cross fittings, C is the larger of the two taps.)
c or d	-	Branch tap minor axis
t	-	Insulation/liner thickness
R	-	Centerline radius
S	-	Slip-fit dimension of a fitting
F, H, J, L, Q, V, Z, m, α	-	Miscellaneous dimensions (refer to specific drawings)
θ or φ	-	Angular measurements (refer to specific drawings)
#	-	Number of elbow gores

General Notes:

- Dimensions other than minor and major axes are held within a 1/4-inch tolerance.
- The major axis is the greater dimension; the minor axis is the smaller dimension.

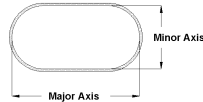

- Unless ordered otherwise, the inner liners and outer shells of double-wall, flat oval fittings are sized to slip fit into the inner liners and outer shells of double-wall, flat oval duct.
- Double-wall fittings ordered for slip-fit assembly have a projecting inner liner slip-fit section as shown in the following drawing:

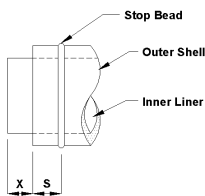

Where: S = 2 inches
X = 1 inch for inner liner minor axis dimensions less than or equal to 7 inches
X = 2 inches for inner liner minor axis dimensions greater than 7 inches

- Double-wall duct and fittings can be ordered with Van Stone or applied connectors installed on the outer shell. For these cases the inner liner does not project beyond the outer shell (X=0 inches) and a slip-fit single-wall coupling or safe-off should be ordered to align the inner liners of mating duct and fittings. Van Stone connectors change the makeup dimensions of standard slip-fit dimension ends. Refer to details on page 46 for further information.
- Unless ordered otherwise, the branch taps of laterals, crosses, lateral crosses, and Y-fittings are installed at standard angles to the fittings' bodies and to each other, as shown in the following drawings:

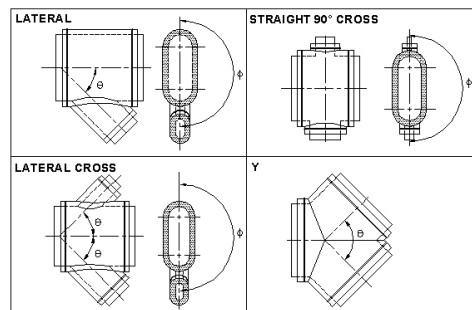

For all:

Laterals, θ standard = 45°
 Crosses, θ standard = 90° , ϕ standard = 180°
 Lateral Crosses, θ standard = 45° , ϕ standard = 180°
 Y-Fittings, θ standard = 90°

Note: ϕ is the included angle between taps as viewed in cross section (standard is 180°). When ordering fittings of nonstandard ϕ , please include an end view.

General Notes:

- When ordering fittings of a nonstandard shape (such as one of those shown in the following examples), please include a drawing with all necessary dimensions:

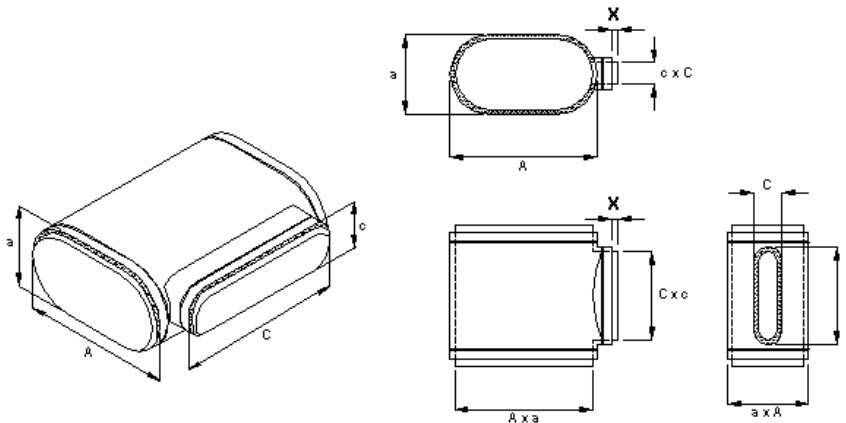

Example 1 (default)

Tap is centered off the minor and the major dimension of tap is along the fitting body (mina)

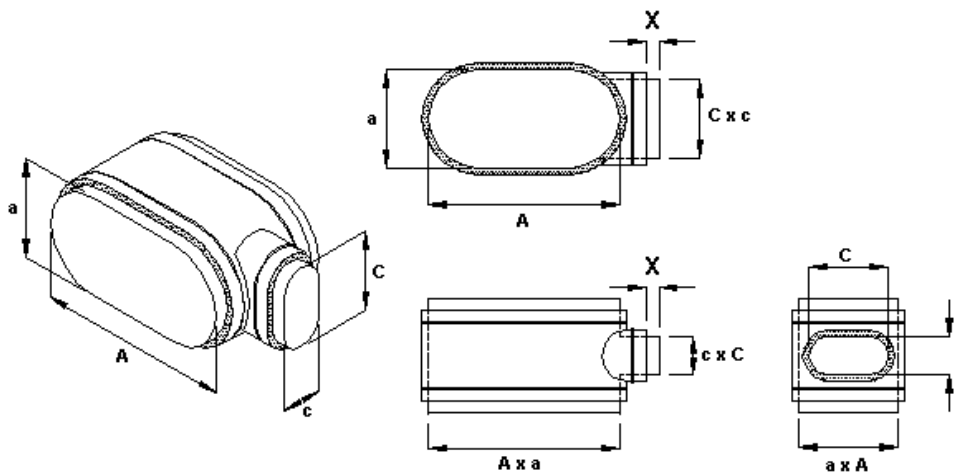

Example 2

Tap is centered off the minor and the minor dimension of tap is along the fitting body (minx)

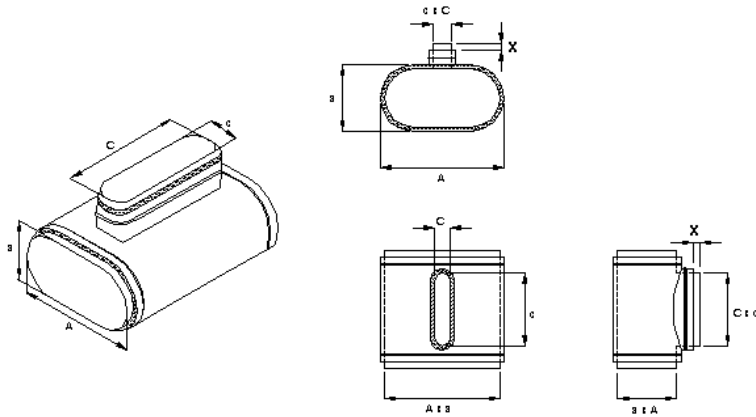

Example 3

Tap is centered off the major and the major dimension of tap is along the fitting body (maja)

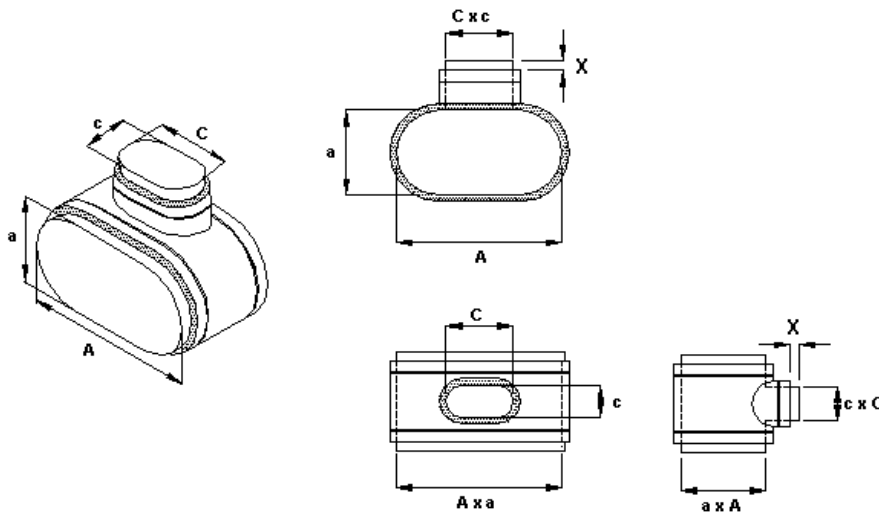

Example 4

Tap is centered off the major and the minor dimension of tap is along the fitting body (majx)

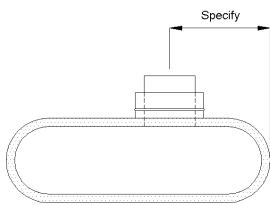

Example 5

Tap is not centered on the major axis; specify dimension shown

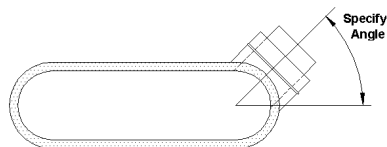

Example 6

Tap is not centered on the minor axis; specify dimension shown

- Reducing fitting dimensions are determined by combining the nonreducing fitting body with the appropriate reducer eliminating the S and X dimensions on the downstream section of the fitting and the upstream section of the reducer. Examples are shown below:

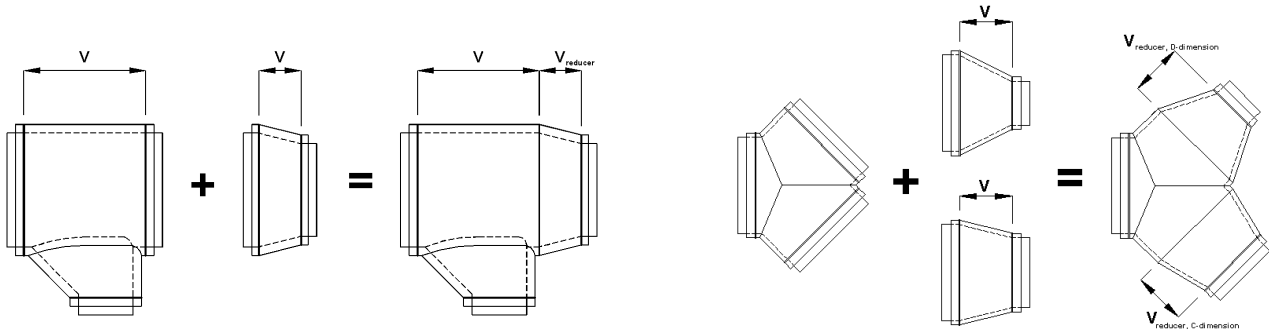

Example 1: Reducing LO-LOSS Tee

Example 2: Reducing Y

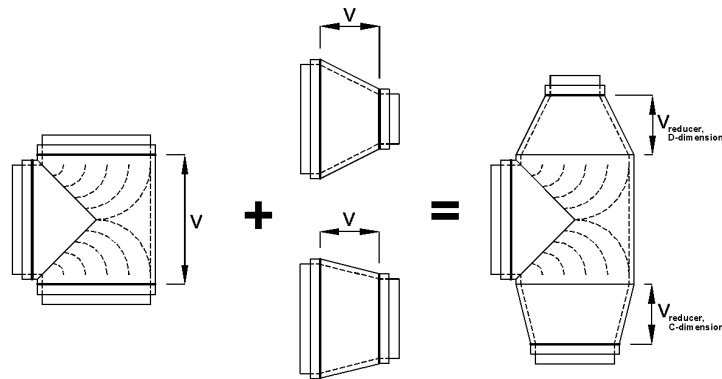

Example 3: Reducing Bullhead Tee with Turning Vanes

- If reducers are not concentric, please include an end view.
- For installation information, refer to McGill AirFlow's brochure *Installation of Double-wall Duct and Fittings*.
- Round and rectangular taps are available in lieu of flat oval. Specify tap dimension.
- The Q dimension of laterals and lateral crosses may be less than, equal to, or greater than the V dimension of these fittings.

Designations:

McGill AirFlow uses a designation system that simplifies product nomenclature. Most of our products can be accurately identified using a concise alphanumeric designator. Each character in the designation defines a characteristic of the product.

Example: KOST refers to a double-wall (K), oval (O), standard gauge (S), straight tee (T).

1st Character: **Wall Configuration** - KOST

S = Single-wall
K = k27 Double-wall

2nd Character: **Shape** - KOST

R = Round
O = Oval

3rd Character: **Product Line** - KOST

S = Standard gauge of product type
N = Nonstandard gauge (user specified)

Notes: 1. When ordering duct or fittings, specify S or N in the * position of the designation.

4th and Subsequent Characters: **Product Type** - KOST

T = Straight Tee (90° branch fitting)

Table 4 - Thickness/Weight Relationships of Standard Materials

Gauge	Galvanized and Paintable Galvanized Steel			Nongalvanized Carbon Steel			Stainless Steel (304 or 316)		
	Minimum Thickness (inches)	Nominal Thickness (inches)	Nominal Weight (lb/sq ft)	Minimum Thickness (inches)	Nominal Thickness (inches)	Nominal Weight (lb/sq ft)	Minimum Thickness (inches)	Nominal Thickness (inches)	Nominal Weight (lb/sq ft)
28	0.0157	0.0187	0.781	0.0129	0.0149	0.625	0.0136	0.0156	0.656
26	0.0187	0.0217	0.906	0.0159	0.0179	0.750	0.0158	0.0188	0.788
24	0.0236	0.0276	1.156	0.0209	0.0239	1.000	0.0220	0.0250	1.050
22	0.0296	0.0336	1.406	0.0269	0.0299	1.250	0.0273	0.0313	1.313
20	0.0356	0.0396	1.656	0.0329	0.0359	1.500	0.0335	0.0375	1.575
18	0.0466	0.0516	2.156	0.0438	0.0478	2.000	0.0450	0.0500	2.100
16	0.0575	0.0635	2.656	0.0548	0.0598	2.500	0.0565	0.0625	2.625
14	0.0705	0.0785	3.281	0.0697	0.0747	3.125	0.0711	0.0781	3.281
12	0.0994	0.1084	4.531	0.0986	0.1046	4.375	0.1000	0.1094	4.594
10	0.1292	0.1382	5.781	0.1285	0.1345	5.625	0.1286	0.1406	5.906

Aluminum 3003-H14		
Minimum Thickness (inches)	Nominal Thickness (inches)	Nominal Weight (lb/sq ft)
0.0230	0.025	0.356
0.0295	0.032	0.456
0.0365	0.040	0.570
0.0465	0.050	0.713
0.0595	0.063	0.898
0.0755	0.080	1.140
0.0855	0.090	1.283
0.0945	0.100	1.426
0.1195	0.125	1.782

Table 5 - Double-Wall, Flat Oval Duct and Fittings - Available Dimensions

Inner Minor Axis (inches)	Spiral Lockseam						Longitudinal Seam	
	Minimum Inner Major Axis (inches)			Maximum Inner Major Axis (inches)			Minimum Inner Major Axis (inches)	Maximum Inner Major Axis (inches)
	Insulation Thickness			Insulation Thickness				
1"	2"	3"	1"	2"	3"			
3	8	8	8	19	19	17	22	30
4	7	7	7	21	21	21	23	40
5	8	8	8	21	19	19	24	46
6	8	8	8	59	59	59	na	na
7	10	10	na	21	21	na	23	62
8	10	10	11	77	77	74	na	na
9	12	na	na	23	na	na	26	89
10	12	13	13	79	76	73	84	99
11	na	na	na	na	na	na	14	109
12	18	17	17	78	75	75	78	119
14	20	20	20	77	77	74	84	139
16	22	22	29	79	76	76	85	143
18	24	31	31	78	78	75	87	134
20	33	33	na	80	77	na	85	140
22	35	na	na	79	na	na	84	134
24	not available						37	141
26							29	137
28							31	144
30							33	141
32							35	139
34							37	138
36							39	136
38							41	136
40							43	143

Table 6 - Material Specifications

Standard Material	Type	ASTM Number
Galvanized Steel	--	A653, A924
Stainless Steel	304, 304L, 316, 316L	A167, A480
Nongalvanized Carbon Steel	18 - 28 gauge	A366, A568, A569
Aluminum	3003-H14	B209
Aluminized	Type 1	A463

Other types of material are available on special order.

Table 7 - McGill AirFlow Standard Construction Methods

Product	Construction
ACOUSTI-k27 Duct	Spiral lockseam
Longitudinal Seam-k27 Duct	Rolled and butt welded
ACOUSTI-k27 Fittings	Standard: Spot/tack welded. Available fully welded.

Table 8 - Double-wall, Flat Oval Spiral Duct and Fittings: standard major axis/thickness relationships of duct and fittings fabricated from galvanized, paintable galvanized, or nongalvanized carbon steel.²

Outer Major Axis (inches)	Duct Thickness (gauge)		Fitting Thickness (gauge)
	KOSSD	KOSLD	KOS__
7 - 8	24	20	20
9 - 24	24	20	20
25 - 30	22	20	20
31 - 36	22	20	20
37 - 42	22	18	18
43 - 48	22	18	18
49	20	18	18
50 - 60	20	18	18
61 - 68	20	16	16
69 - 70	20	16	16
71 - 83	18	16	16
84 - 120	na	16	16

Table 9 - Double-Wall, Flat Oval Spiral Duct and Fittings: standard major axis/thickness relationships of duct and fittings fabricated from type 304 or 316 stainless steel.^{1,2}

Outer Major Axis (inches)	Duct Thickness (inches)		Fitting Thickness (inches)
	KOSSD	KOSLD	KOS__
8 -24	24	20	20
25 - 36	22	20	20
37 - 48	22	18	18
49 - 60	20	18	18
61 - 70	20	16	16
71 - 120	na	16	16

Table 10 - Double-Wall, Flat Oval Spiral Duct and Fittings: standard major axis/thickness relationships of duct and fittings fabricated from type 3003-H14 aluminum.^{1,3}

Outer Major Axis (inches)	Duct Thickness (inches)		Fitting Thickness (gauge)
	KOSSD	KOSLD	KOS__
7 - 8	0.040	0.063	0.063
9 - 24	0.040	0.063	0.063
25 - 36	0.050	0.063	0.063
37 - 42	0.050	0.080	0.080
43 - 48	0.050	0.080	0.080
49 - 60	0.063	0.080	0.080
61 - 70	0.063	na	na

Notes for Tables 8 through 10:

1. Note: na = not available
2. McGill AirFlow does not have standard material major axis/thickness relationships for major axes greater than 120 inches. Please specify the required material thickness when ordering.
3. Aluminum thickness for KOSSD duct, and KOS__ fittings is based on approximately 1.5 times galvanized steel thickness standards in these product lines, for equal strength and stiffness.
4. Contact McGill AirFlow for assistance in designing flat oval duct systems in negative pressure applications exceeding -2 in wg.
5. All gauges listed in Tables 8 through 10 are good for operating pressures up to + 10 in wg.

Table 11 - Double-wall, Flat Oval Duct and Fittings: standard basic round/thickness relationships of inner liners.

Inner Liner Basic Round ⁴ Diameter (inches)	Duct Inner Liner Thickness (gauge)	Duct ^{1,3} Inner Liner Construction	Fitting ^{2,3} Inner Liner Thickness (gauge)
3 - 8 ½	28	nonribbed	24
9 - 34	28	ribbed	24
35 - 42	28	ribbed	22
44 - 58	26	ribbed	22
60	26	ribbed	20
62 - 84	22	nonribbed	20

- Note:**
1. Standard inner liner for all duct is perforated wall, galvanized, regardless of the outer shell material.
 2. Standard inner liner for all fittings is solid wall, galvanized, regardless of the outer shell material.
 3. Other inner liner materials are available on special order. The inner liner of duct can be ordered as solid wall. The inner liner of fittings can be ordered as perforated wall.
 4. Gauges are based on the Basic Round dimension. The Basic Round dimension is calculated from:

$$\text{Basic Round of Inner Shell} = \frac{(\pi \times \text{Minor}) + 2(\text{Major} - \text{Minor})}{\pi}$$

FLAT OVAL ACOUSTI-k27 DUCT (Spiral lockseam)

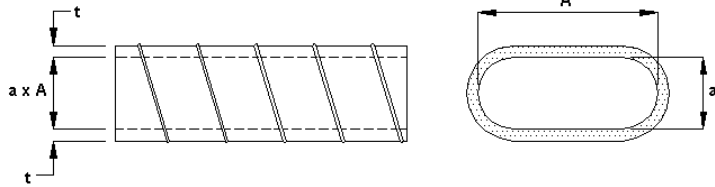

DESIGNATION:
KO(*)SD

DIMENSIONS:
(See Tables 5 and 12)

LONGITUDINAL SEAM-k27 FLAT OVAL DUCT (Fully welded longitudinal seam)

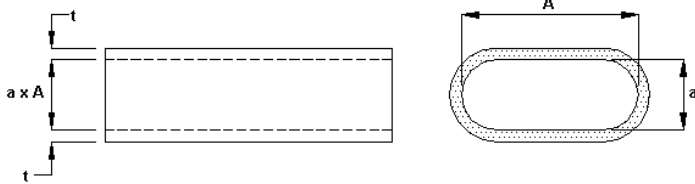

DESIGNATION:
KO(*)LD

DIMENSIONS:
(See Table 5)

Table 12- Dimensions and Properties

Inner Nominal Size (inches)	Approximate Equivalent Rectangular (inches)	Equivalent Diameter ¹ (inches)	Cross Sectional Area (ft ²)	Outer Surface Area Per Foot 1"-k27 (ft ² /ft)	Weight per Foot ² 1"-k27 (lbs./ft)	Outer Surface Area Per Foot 2"-k27 (ft ² /ft)	Weight per Foot ² 2"-k27 (lbs./ft)	Outer Surface Area Per Foot 3"-k27 (ft ² /ft)	Weight per Foot ² 3"-k27 (lbs./ft)	Availability		
										1" -k27	2" -k27	3" -k27
3 x 8*	3 x 8	5.1	0.15	2.09	4.04	2.62	4.78	3.14	5.52	X	X	X
3 x 9*	3 x 9	5.6	0.19	2.36	4.60	2.88	5.34	3.40	6.07	X	X	X
3 x 11*	3 x 11	6.0	0.22	2.62	5.15	3.14	5.89	3.66	6.63	X	X	X
3 x 12*	3 x 12	6.4	0.25	2.88	5.70	3.40	6.44	3.93	7.18	X	X	X
3 x 14*	3 x 14	6.7	0.29	3.14	6.25	3.66	6.99	4.19	7.73	X	X	X
3 x 17*	3 x 17	7.3	0.36	3.67	7.35	4.19	8.09	4.71	8.83	X	X	X
3 x 19*	3 x 19	7.6	0.39	3.93	7.90	4.45	8.64			X	X	--
4 x 7*	4 x 7	5.6	0.18	2.10	4.05	2.62	4.79	3.14	5.53	X	X	X
4 x 9*	4 x 8	6.2	0.22	2.36	4.60	2.88	5.34	3.40	6.08	X	X	X
4 x 10*	4 x 10	6.7	0.26	2.62	5.15	3.14	5.89	3.67	6.63	X	X	X
4 x 12*	4 x 12	7.2	0.31	2.88	5.70	3.40	6.44	3.93	7.18	X	X	X
4 x 13*	4 x 13	7.6	0.35	3.14	6.25	3.67	6.99	4.19	7.73	X	X	X
4 x 15*	4 x 15	8.0	0.39	3.41	6.80	3.93	7.54	4.45	8.28	X	X	X
4 x 17*	4 x 16	8.3	0.44	3.67	7.36	4.19	8.09	4.71	8.83	X	X	X
4 x 18*	4 x 18	8.7	0.48	3.93	7.91	4.45	8.65	4.98	9.39	X	X	X
4 x 20*	4 x 20	9.0	0.53	4.19	8.46	4.71	9.20	5.24	11.44	X	X	X
4 x 21*	4 x 21	9.3	0.57	4.45	9.01	4.98	9.75	5.50	12.07	X	X	X
5 x 8*	5 x 8	6.6	0.25	2.36	4.60	2.88	5.34	3.40	6.07	X	X	X
5 x 10*	5 x 9	7.3	0.30	2.62	5.15	3.14	5.89	3.66	6.63	X	X	X
5 x 11*	5 x 11	7.9	0.35	2.88	5.70	3.40	6.44	3.93	7.18	X	X	X
5 x 13*	5 x 13	8.4	0.41	3.14	6.25	3.66	6.99	4.19	7.73	X	X	X
5 x 14*	5 x 14	8.8	0.46	3.40	6.80	3.93	7.54	4.45	8.28	X	X	X
5 x 16*	5 x 16	9.3	0.52	3.67	7.35	4.19	8.09	4.71	8.83	X	X	X
5 x 18*	5 x 17	9.7	0.57	3.93	7.90	4.45	8.64	4.97	9.38	X	X	X
5 x 19*	5 x 19	10.0	0.63	4.19	8.45	4.71	9.19	5.24	11.44	X	X	X
5 x 21*	5 x 21	10.4	0.68	4.45	9.00					X	--	--
6 x 8*	6 x 8	6.9	0.26	2.35	4.59	2.88	5.33	3.40	6.07	X	X	X
6 x 9*	6 x 9	7.7	0.33	2.62	5.14	3.14	5.88	3.66	6.62	X	X	X
6 x 11*	6 x 10	8.4	0.39	2.88	5.69	3.40	6.43	3.93	7.17	X	X	X
6 x 12*	6 x 12	9.0	0.46	3.14	6.24	3.66	6.98	4.19	7.72	X	X	X
6 x 14*	6 x 13	9.5	0.52	3.40	6.80	3.92	7.53	4.45	8.27	X	X	X
6 x 15*	6 x 15	10.0	0.59	3.66	7.35	4.19	8.09	4.71	8.83	X	X	X

Table 12- Dimensions and Properties

Inner Nominal Size (inches)	Approximate Equivalent Rectangular (inches)	Equivalent Diameter ¹ (inches)	Cross Sectional Area (ft ²)	Outer Surface Area Per Foot 1"-k27 (ft ² /ft)	Weight per Foot ² 1"-k27 (lbs./ft)	Outer Surface Area Per Foot 2"-k27 (ft ² /ft)	Weight per Foot ² 2"-k27 (lbs./ft)	Outer Surface Area Per Foot 3"-k27 (ft ² /ft)	Weight per Foot ² 3"-k27 (lbs./ft)	Availability		
										1" -k27	2" -k27	3" -k27
6 x 17*	6 x 17	10.5	0.65	3.93	7.90	4.45	8.64	4.97	9.38	X	X	X
6 x 19*	6 x 18	10.9	0.72	4.19	8.45	4.71	9.19	5.24	11.44	X	X	X
6 x 20*	6 x 20	11.4	0.78	4.45	9.00	4.97	9.74	5.50	12.06	X	X	X
6 x 22	6 x 21	11.8	0.85	4.71	9.55	5.23	11.80	5.76	12.69	X	X	X
6 x 23	6 x 23	12.1	0.91	4.97	11.53	5.50	12.42	6.02	13.31	X	X	X
6 x 25	6 x 25	12.5	0.98	5.23	12.16	5.76	13.05	6.28	13.94	X	X	X
6 x 26	6 x 26	12.8	1.04	5.50	12.78	6.02	13.67	6.54	14.56	X	X	X
6 x 28	6 x 28	13.1	1.11	5.76	13.41	6.28	14.30	6.81	15.19	X	X	X
6 x 30	6 x 29	13.5	1.18	6.02	14.04	6.54	14.93	7.07	15.82	X	X	X
6 x 31	6 x 31	13.8	1.24	6.28	14.66	6.80	15.55	7.33	16.44	X	X	X
6 x 33	6 x 33	14.0	1.31	6.54	15.29	7.07	16.18	7.59	17.07	X	X	X
6 x 34	6 x 34	14.3	1.37	6.80	15.91	7.33	16.80	7.85	17.69	X	X	X
6 x 36	6 x 36	14.6	1.44	7.07	16.54	7.59	17.43			X	X	--
6 x 37	6 x 37	14.9	1.50	7.33	17.17	7.85	18.06	8.38	18.95	X	X	X
6 x 41	6 x 40	15.4	1.63	7.85	18.42	8.38	19.31	8.90	20.20	X	X	X
6 x 44	6 x 44	15.9	1.76	8.38	19.67	8.90	20.56	9.42	24.16	X	X	X
6 x 47	6 x 47	16.3	1.89	8.90	23.48	9.42	24.52	9.95	25.56	X	X	X
6 x 50	6 x 50	16.8	2.02	9.42	24.88	9.95	25.93	10.47	26.97	X	X	X
6 x 53	6 x 53	17.2	2.15	9.95	26.29	10.47	27.33	10.99	28.37	X	X	X
6 x 56	6 x 56	17.6	2.29	10.47	27.69	10.99	28.73	11.52	29.78	X	X	X
6 x 59	6 x 60	18.0	2.42	10.99	29.10	11.52	30.14	12.04	31.18	X	X	X
7 x 10*	7 x 9	8.7	0.42	2.88	5.70	3.40	6.44			X	X	--
7 x 12*	7 x 11	9.4	0.50	3.14	6.25	3.67	6.99			X	X	--
7 x 13*	7 x 13	10.1	0.57	3.40	6.80	3.93	7.54			X	X	--
7 x 15*	7 x 14	10.7	0.65	3.67	7.35	4.19	8.09			X	X	--
7 x 16*	7 x 16	11.2	0.73	3.93	7.90	4.45	8.64			X	X	--
7 x 18*	7 x 17	11.7	0.80	4.19	8.46	4.71	9.20			X	X	--
7 x 20*	7 x 19	12.2	0.88	4.45	9.01	4.98	9.75			X	X	--
7 x 21*	7 x 21	12.6	0.96	4.71	9.56	5.24	11.80			X	X	--
8 x 10*	8 x 9	8.9	0.44	2.88	5.70	3.40	6.44			X	X	--
8 x 11*	8 x 10	9.8	0.52	3.14	6.25	3.66	6.99	4.19	7.73	X	X	X
8 x 13*	8 x 12	10.5	0.61	3.40	6.80	3.93	7.54	4.45	8.28	X	X	X
8 x 14*	8 x 13	11.2	0.70	3.66	7.35	4.19	8.09	4.71	8.83	X	X	X

Table 12- Dimensions and Properties

Inner Nominal Size (inches)	Approximate Equivalent Rectangular (inches)	Equivalent Diameter ¹ (inches)	Cross Sectional Area (ft ²)	Outer Surface Area Per Foot 1"-k27 (ft ² /ft)	Weight per Foot ² 1"-k27 (lbs./ft)	Outer Surface Area Per Foot 2"-k27 (ft ² /ft)	Weight per Foot ² 2"-k27 (lbs./ft)	Outer Surface Area Per Foot 3"-k27 (ft ² /ft)	Weight per Foot ² 3"-k27 (lbs./ft)	Availability		
										1" -k27	2" -k27	3" -k27
8 x 16*	8 x 15	11.8	0.78	3.93	7.90	4.45	8.64	4.97	9.38	X	X	X
8 x 17*	8 x 17	12.3	0.87	4.19	8.45	4.71	9.19	5.23	9.93	X	X	X
8 x 19*	8 x 18	12.9	0.96	4.45	9.00	4.97	9.74	5.50	12.06	X	X	X
8 x 21	8 x 20	13.4	1.05	4.71	9.55	5.24	11.80	5.76	12.69	X	X	X
8 x 22	8 x 22	13.9	1.13	4.97	10.10	5.50	12.42	6.02	13.32	X	X	X
8 x 24	8 x 23	14.3	1.22	5.24	12.16	5.76	13.05	6.28	13.94	X	X	X
8 x 25	8 x 25	14.7	1.31	5.50	12.79	6.02	13.68	6.54	14.57	X	X	X
8 x 27	8 x 26	15.1	1.40	5.76	13.41	6.28	14.30	6.81	15.19	X	X	X
8 x 30	8 x 30	15.9	1.57	6.28	14.66	6.81	15.55	7.33	16.44	X	X	X
8 x 32	8 x 31	16.3	1.66	6.54	15.29	7.07	16.18	7.59	17.07	X	X	X
8 x 33	8 x 33	16.6	1.74	6.81	15.92	7.33	16.81	7.85	17.70	X	X	X
8 x 35	8 x 34	17.0	1.83	7.07	16.54	7.59	17.43			X	X	--
8 x 36	8 x 36	17.3	1.92	7.33	17.17	7.85	18.06	8.38	18.95	X	X	X
8 x 38	8 x 37	17.6	2.01	7.59	17.80					X	--	--
8 x 39	8 x 39	17.9	2.09	7.85	18.42	8.38	19.31	8.90	20.20	X	X	X
8 x 43	8 x 42	18.5	2.27	8.38	19.67	8.90	20.56	9.42	24.16	X	X	X
8 x 46	8 x 45	19.1	2.44	8.90	20.93	9.42	24.53	9.95	25.57	X	X	X
8 x 49	8 x 49	19.7	2.62	9.42	24.89	9.95	25.93	10.47	26.97	X	X	X
8 x 52	8 x 52	20.2	2.79	9.95	26.29	10.47	27.33	10.99	28.37	X	X	X
8 x 55	8 x 55	20.7	2.96	10.47	27.69	10.99	28.73	11.52	29.77	X	X	X
8 x 58	8 x 58	21.1	3.14	11.00	29.10	11.52	30.14	12.04	31.18	X	X	X
8 x 61	8 x 61	21.6	3.31	11.52	30.50	12.04	31.54	12.57	32.58	X	X	X
8 x 65	8 x 64	22.1	3.49	12.04	33.18	12.57	34.22	13.09	42.79	X	X	X
8 x 68	8 x 68	22.5	3.66	12.57	34.64	13.09	43.20	13.61	44.55	X	X	X
8 x 71	8 x 71	22.9	3.84	13.09	43.62	13.61	44.97	14.14	46.31	X	X	X
8 x 74	8 x 74	23.3	4.01	13.61	45.39	14.14	46.73	14.66	48.07	X	X	X
8 x 77	8 x 77	23.7	4.19	14.14	47.15	14.66	48.49			X	X	--
9 x 12*	9 x 11	10.8	0.64	3.40	6.80					X	--	--
9 x 14*	9 x 13	11.5	0.74	3.67	7.35					X	--	--
9 x 15*	9 x 14	12.2	0.84	3.93	7.90					X	--	--
9 x 17*	9 x 16	12.9	0.93	4.19	8.45					X	--	--
9 x 18*	9 x 18	13.5	1.03	4.45	9.00					X	--	--
9 x 20*	9 x 19	14.0	1.13	4.71	9.56					X	--	--

Table 12- Dimensions and Properties

Inner Nominal Size (inches)	Approximate Equivalent Rectangular (inches)	Equivalent Diameter ¹ (inches)	Cross Sectional Area (ft ²)	Outer Surface Area Per Foot 1"-k27 (ft ² /ft)	Weight per Foot ² 1"-k27 (lbs./ft)	Outer Surface Area Per Foot 2"-k27 (ft ² /ft)	Weight per Foot ² 2"-k27 (lbs./ft)	Outer Surface Area Per Foot 3"-k27 (ft ² /ft)	Weight per Foot ² 3"-k27 (lbs./ft)	Availability		
										1" -k27	2" -k27	3" -k27
9 x 22*	9 x 21	14.6	1.23	4.98	10.11					X	--	--
9 x 23*	9 x 22	15.1	1.33	5.24	12.17					X	--	--
10 x 12*	10 x 10	11.0	0.65	3.40	6.80					X	--	--
10 x 13*	10 x 12	11.8	0.76	3.66	7.35	4.19	8.09	4.71	8.83	X	X	X
10 x 15*	10 x 14	12.6	0.87	3.93	7.90	4.45	8.64	4.97	9.38	X	X	X
10 x 16*	10 x 15	13.3	0.98	4.19	8.45	4.71	9.19	5.24	9.93	X	X	X
10 x 18*	10 x 17	14.0	1.09	4.45	9.00	4.97	9.74	5.50	10.48	X	X	X
10 x 19*	10 x 18	14.6	1.20	4.71	9.55	5.24	10.29	5.76	12.69	X	X	X
10 x 21*	10 x 20	15.2	1.31	4.97	10.11	5.50	12.43	6.02	13.32	X	X	X
10 x 23	10 x 22	15.7	1.42	5.24	12.16	5.76	13.05	6.28	13.94	X	X	X
10 x 24	10 x 23	16.2	1.53	5.50	12.79	6.02	13.68	6.55	14.57	X	X	X
10 x 26	10 x 25	16.7	1.64	5.76	13.41	6.28	14.30	6.81	15.20	X	X	X
10 x 27	10 x 26	17.2	1.75	6.02	14.04	6.55	14.93	7.07	15.82	X	X	X
10 x 29	10 x 28	17.7	1.85	6.28	14.67	6.81	15.56	7.33	16.45	X	X	X
10 x 30	10 x 30	18.1	1.96	6.54	15.29	7.07	16.18	7.59	17.07	X	X	X
10 x 32	10 x 31	18.5	2.07	6.81	15.92	7.33	16.81	7.85	17.70	X	X	X
10 x 34	10 x 33	18.9	2.18	7.07	16.54	7.59	17.43			X	X	--
10 x 35	10 x 34	19.3	2.29	7.33	17.17	7.85	18.06	8.38	18.95	X	X	X
10 x 37	10 x 36	19.7	2.40	7.59	17.80					X	--	--
10 x 38	10 x 38	20.1	2.51	7.85	18.42	8.38	19.31	8.90	20.20	X	X	X
10 x 40	10 x 39	20.4	2.62	8.12	19.05					X	--	--
10 x 41	10 x 41	20.8	2.73	8.38	19.68	8.90	20.57	9.43	21.46	X	X	X
10 x 45	10 x 44	21.5	2.95	8.90	20.93	9.43	24.53	9.95	25.57	X	X	X
10 x 51	10 x 50	22.7	3.38	9.95	26.29	10.47	27.33	11.00	28.37	X	X	X
10 x 54	10 x 54	23.3	3.60	10.47	27.69	11.00	28.74	11.52	29.78	X	X	X
10 x 57	10 x 57	23.9	3.82	10.99	29.10	11.52	30.14	12.04	31.18	X	X	X
10 x 60	10 x 60	24.4	4.04	11.52	30.50	12.04	31.54	12.57	32.58	X	X	X
10 x 63	10 x 63	25.0	4.25	12.04	33.18	12.57	34.22	13.09	35.26	X	X	X
10 x 67	10 x 66	25.5	4.47	12.57	34.64	13.09	43.21	13.61	44.55	X	X	X
10 x 70	10 x 69	26.0	4.69	13.09	43.63	13.61	44.97	14.14	46.31	X	X	X
10 x 73	10 x 73	26.4	4.91	13.61	45.39	14.14	46.73	14.66	48.07	X	X	X
10 x 76	10 x 76	26.9	5.13	14.14	47.15	14.66	48.49			X	X	--
10 x 79	10 x 79	27.3	5.35	14.66	48.92					X	--	--

Table 12- Dimensions and Properties

Inner Nominal Size (inches)	Approximate Equivalent Rectangular (inches)	Equivalent Diameter ¹ (inches)	Cross Sectional Area (ft ²)	Outer Surface Area Per Foot 1"-k27 (ft ² /ft)	Weight per Foot ² 1"-k27 (lbs./ft)	Outer Surface Area Per Foot 2"-k27 (ft ² /ft)	Weight per Foot ² 2"-k27 (lbs./ft)	Outer Surface Area Per Foot 3"-k27 (ft ² /ft)	Weight per Foot ² 3"-k27 (lbs./ft)	Availability		
										1" -k27	2" -k27	3" -k27
12 x 17*	12 x 15	14.6	1.18			4.97	9.74	5.50	10.48	--	X	X
12 x 18*	12 x 17	15.4	1.31	4.71	9.55	5.24	10.29	5.76	11.03	X	X	X
12 x 20*	12 x 18	16.1	1.44	4.97	10.11	5.50	10.85	6.02	13.32	X	X	X
12 x 21*	12 x 20	16.7	1.57	5.24	10.66	5.76	13.05	6.28	13.94	X	X	X
12 x 23*	12 x 22	17.4	1.70	5.50	12.79	6.02	13.68	6.55	14.57	X	X	X
12 x 25	12 x 23	18.0	1.83	5.76	13.42	6.28	14.31	6.81	15.20	X	X	X
12 x 26	12 x 25	18.5	1.96	6.02	14.04	6.55	14.93	7.07	15.82	X	X	X
12 x 28	12 x 27	19.1	2.10	6.28	14.67	6.81	15.56	7.33	16.45	X	X	X
12 x 29	12 x 28	19.6	2.23	6.55	15.29	7.07	16.18	7.59	17.08	X	X	X
12 x 31	12 x 30	20.1	2.36	6.81	15.92	7.33	16.81	7.85	17.70	X	X	X
12 x 32	12 x 31	20.6	2.49	7.07	16.55	7.59	17.44			X	X	--
12 x 34	12 x 33	21.0	2.62	7.33	17.17	7.85	18.06	8.38	18.95	X	X	X
12 x 36	12 x 35	21.5	2.75	7.59	17.80					X	--	--
12 x 37	12 x 36	21.9	2.88	7.85	18.42	8.38	19.31	8.90	20.20	X	X	X
12 x 39	12 x 38	22.3	3.01	8.12	19.05					X	--	--
12 x 40	12 x 39	22.7	3.14	8.38	19.68	8.90	20.57	9.42	21.46	X	X	X
12 x 43	12 x 43	23.5	3.41	8.90	20.93	9.43	21.82	9.95	25.57	X	X	X
12 x 47	12 x 46	24.2	3.67	9.43	24.89	9.95	25.93	10.47	26.97	X	X	X
12 x 50	12 x 49	25.0	3.93	9.95	26.30	10.47	27.34	11.00	28.38	X	X	X
12 x 53	12 x 52	25.6	4.19	10.47	27.70	11.00	28.74	11.52	29.78	X	X	X
12 x 56	12 x 55	26.3	4.45	11.00	29.10	11.52	30.14	12.04	31.18	X	X	X
12 x 59	12 x 58	26.9	4.72	11.52	30.50	12.04	31.54	12.57	32.58	X	X	X
12 x 62	12 x 62	27.5	4.98	12.04	33.18	12.57	34.22	13.09	35.26	X	X	X
12 x 65	12 x 65	28.1	5.24	12.57	34.64	13.09	35.68	13.61	44.55	X	X	X
12 x 69	12 x 68	28.7	5.50	13.09	43.63	13.61	44.97	14.14	46.31	X	X	X
12 x 72	12 x 71	29.2	5.76	13.61	45.39	14.14	46.73	14.66	48.08	X	X	X
12 x 75	12 x 74	29.7	6.03	14.14	47.15	14.66	48.49	15.18	49.84	X	X	X
12 x 78	12 x 78	30.3	6.29	14.66	48.91					X	--	--
14 x 20	14 x 19	17.5	1.68	5.24	10.66	5.76	11.40	6.28	13.94	X	X	X
14 x 22	14 x 20	18.2	1.83	5.50	11.21	6.02	13.68	6.55	14.57	X	X	X
14 x 23	14 x 22	18.9	1.99	5.76	13.42	6.28	14.31	6.81	15.20	X	X	X
14 x 25	14 x 23	19.5	2.14	6.02	14.05	6.55	14.94	7.07	15.83	X	X	X
14 x 27	14 x 25	20.2	2.29	6.29	14.67	6.81	15.56	7.33	16.45	X	X	X

Table 12- Dimensions and Properties

Inner Nominal Size (inches)	Approximate Equivalent Rectangular (inches)	Equivalent Diameter ¹ (inches)	Cross Sectional Area (ft ²)	Outer Surface Area Per Foot 1"-k27 (ft ² /ft)	Weight per Foot ² 1"-k27 (lbs./ft)	Outer Surface Area Per Foot 2"-k27 (ft ² /ft)	Weight per Foot ² 2"-k27 (lbs./ft)	Outer Surface Area Per Foot 3"-k27 (ft ² /ft)	Weight per Foot ² 3"-k27 (lbs./ft)	Availability		
										1" -k27	2" -k27	3" -k27
14 x 28	14 x 27	20.8	2.45	6.55	15.30	7.07	16.19	7.59	17.08	X	X	X
14 x 30	14 x 28	21.3	2.60	6.81	15.92	7.33	16.81	7.86	17.70	X	X	X
14 x 31	14 x 30	21.9	2.75	7.07	16.55	7.59	17.44			X	X	--
14 x 33	14 x 31	22.4	2.90	7.33	17.17	7.86	18.06	8.38	18.96	X	X	X
14 x 34	14 x 33	22.9	3.06	7.59	17.80					X	--	---
14 x 36	14 x 35	23.4	3.21	7.86	18.43	8.38	19.32	8.90	20.21	X	X	X
14 x 39	14 x 38	24.4	3.52	8.38	19.68	8.90	20.57	9.43	21.46	X	X	X
14 x 42	14 x 41	25.3	3.82	8.90	20.93	9.43	21.82	9.95	22.71	X	X	X
14 x 45	14 x 44	26.1	4.13	9.43	22.19	9.95	25.94	10.47	26.98	X	X	X
14 x 49	14 x 47	26.9	4.43	9.95	26.30	10.47	27.34	11.00	28.38	X	X	X
14 x 52	14 x 51	27.7	4.74	10.47	27.70	11.00	28.74	11.52	29.78	X	X	X
14 x 55	14 x 54	28.4	5.04	11.00	29.10	11.52	30.14	12.04	31.18	X	X	X
14 x 58	14 x 57	29.1	5.35	11.52	30.50	12.04	31.55	12.57	32.59	X	X	X
14 x 61	14 x 60	29.8	5.66	12.04	33.18	12.57	34.22	13.09	35.26	X	X	X
14 x 64	14 x 63	30.5	5.96	12.57	34.65	13.09	35.69	13.62	36.73	X	X	X
14 x 67	14 x 67	31.3	6.27	13.09	36.11	13.62	44.98	14.14	46.32	X	X	X
14 x 71	14 x 70	31.7	6.57	13.62	45.40	14.14	46.74	14.66	48.08	X	X	X
14 x 74	14 x 73	32.3	6.88	14.14	47.16	14.66	48.50	15.19	49.84	X	X	X
14 x 77	14 x 76	32.9	7.19	14.66	48.92	15.19	50.26	15.71	51.60	X	X	--
16 x 22	16 x 20	19.5	2.09	5.76	11.75	6.28	14.30			X	X	--
16 x 24	16 x 22	20.3	2.27	6.02	14.03	6.54	14.92			X	X	--
16 x 25	16 x 23	21.0	2.44	6.28	14.66	6.80	15.55			X	X	--
16 x 27	16 x 25	21.7	2.62	6.54	15.29	7.07	16.18			X	X	--
16 x 29	16 x 27	22.3	2.79	6.81	15.92	7.33	16.81	7.85	17.70	X	X	X
16 x 30	16 x 28	22.9	2.96	7.07	16.54	7.59	17.43			X	X	--
16 x 32	16 x 30	23.6	3.14	7.33	17.17	7.85	18.06	8.38	18.95	X	X	X
16 x 33	16 x 32	24.1	3.31	7.59	17.79					X	--	--
16 x 35	16 x 33	24.7	3.49	7.85	18.42	8.38	19.31	8.90	20.20	X	X	X
16 x 38	16 x 36	25.8	3.84	8.38	19.67	8.90	20.56	9.42	21.45	X	X	X
16 x 41	16 x 40	26.8	4.18	8.90	20.92	9.42	21.81	9.95	22.70	X	X	X
16 x 44	16 x 43	27.7	4.53	9.42	22.17	9.95	23.07	10.47	26.97	X	X	X
16 x 47	16 x 46	28.6	4.88	9.95	26.29	10.47	27.33	10.99	28.37	X	X	X
16 x 51	16 x 49	29.5	5.23	10.47	27.69	10.99	28.73	11.52	29.77	X	X	X

Table 12- Dimensions and Properties

Inner Nominal Size (inches)	Approximate Equivalent Rectangular (inches)	Equivalent Diameter ¹ (inches)	Cross Sectional Area (ft ²)	Outer Surface Area Per Foot 1"-k27 (ft ² /ft)	Weight per Foot ² 1"-k27 (lbs./ft)	Outer Surface Area Per Foot 2"-k27 (ft ² /ft)	Weight per Foot ² 2"-k27 (lbs./ft)	Outer Surface Area Per Foot 3"-k27 (ft ² /ft)	Weight per Foot ² 3"-k27 (lbs./ft)	Availability		
										1" -k27	2" -k27	3" -k27
16 x 54	16 x 52	30.3	5.58	10.99	29.09	11.52	30.14	12.04	31.18	X	X	X
16 x 57	16 x 56	31.1	5.93	11.52	30.50	12.04	31.54	12.56	32.58	X	X	X
16 x 60	16 x 59	31.8	6.28	12.04	33.17	12.56	34.21	13.09	35.26	X	X	X
16 x 63	16 x 62	32.6	6.63	12.56	34.63	13.09	35.67	13.61	36.72	X	X	X
16 x 66	16 x 65	33.3	6.98	13.09	36.10	13.61	37.14	14.14	46.31	X	X	X
16 x 69	16 x 68	34.0	7.32	13.61	45.39	14.14	46.73	14.66	48.07	X	X	X
16 x 73	16 x 72	34.6	7.67	14.14	47.15	14.66	48.49	15.18	49.83	X	X	X
16 x 76	16 x 75	35.3	8.02	14.66	48.91	15.18	50.25	15.71	51.59	X	X	X
16 x 79	16 x 78	35.9	8.37	15.18	50.67					X	--	--
18 x 24	18 x 22	21.6	2.55	6.28	14.66					X	--	--
18 x 26	18 x 24	22.3	2.75	6.54	15.29					X	--	--
18 x 27	18 x 25	23.1	2.94	6.81	15.91					X	--	--
18 x 29	18 x 27	23.8	3.14	7.07	16.54					X	--	--
18 x 31	18 x 28	24.5	3.34	7.33	17.17	7.85	18.06	8.38	18.95	X	X	X
18 x 32	18 x 30	25.1	3.53	7.59	17.80					X	--	--
18 x 34	18 x 32	25.7	3.73	7.85	18.42	8.38	19.31	8.90	20.20	X	X	X
18 x 37	18 x 35	26.9	4.12	8.38	19.67	8.90	20.56	9.42	21.45	X	X	X
18 x 40	18 x 38	28.1	4.51	8.90	20.93	9.42	21.82	9.95	22.71	X	X	X
18 x 43	18 x 41	29.1	4.91	9.42	22.18	9.95	23.07	10.47	26.97	X	X	X
18 x 46	18 x 45	30.1	5.30	9.95	23.43	10.47	27.33	10.99	28.37	X	X	X
18 x 49	18 x 48	31.1	5.69	10.47	27.70	11.00	28.74	11.52	29.78	X	X	X
18 x 53	18 x 51	32.0	5.83	10.66	28.20	11.19	29.25	11.71	30.29	X	X	X
18 x 56	18 x 54	32.8	6.48	11.52	30.50	12.04	31.54	12.57	32.58	X	X	X
18 x 59	18 x 57	33.7	6.87	12.04	33.18	12.57	34.22	13.09	35.26	X	X	X
18 x 62	18 x 61	34.5	7.26	12.57	34.64	13.09	35.68	13.61	36.72	X	X	X
18 x 65	18 x 64	35.3	7.65	13.09	36.10	13.61	37.14	14.14	46.31	X	X	X
18 x 68	18 x 67	36.0	8.05	13.61	37.56	14.14	46.73	14.66	48.07	X	X	X
18 x 71	18 x 70	36.7	8.44	14.14	47.15	14.66	48.49			X	X	--
18 x 75	18 x 73	37.4	8.83	14.66	48.91	15.18	50.25	15.71	51.60	X	X	X
18 x 78	18 x 76	38.1	9.22	15.18	50.67	15.71	52.01			X	X	--
20 x 33	20 x 30	26.6	3.93	7.85	18.42	8.38	19.31			X	X	--
20 x 36	20 x 33	27.9	4.36	8.38	19.68	8.90	20.57			X	X	--
20 x 39	20 x 37	29.1	4.80	8.90	20.93	9.42	21.82			X	X	--

Table 12- Dimensions and Properties

Inner Nominal Size (inches)	Approximate Equivalent Rectangular (inches)	Equivalent Diameter ¹ (inches)	Cross Sectional Area (ft ²)	Outer Surface Area Per Foot 1"-k27 (ft ² /ft)	Weight per Foot ² 1"-k27 (lbs./ft)	Outer Surface Area Per Foot 2"-k27 (ft ² /ft)	Weight per Foot ² 2"-k27 (lbs./ft)	Outer Surface Area Per Foot 3"-k27 (ft ² /ft)	Weight per Foot ² 3"-k27 (lbs./ft)	Availability		
										1" -k27	2" -k27	3" -k27
20 x 42	20 x 40	30.3	5.24	9.42	22.18	9.95	23.07			X	X	--
20 x 45	20 x 43	31.4	5.67	9.95	23.43	10.47	27.33			X	X	--
20 x 48	20 x 46	32.5	6.11	10.47	27.69	10.99	28.73			X	X	--
20 x 51	20 x 49	33.5	6.55	11.00	29.10	11.52	30.14			X	X	--
20 x 55	20 x 53	34.4	6.98	11.52	30.50	12.04	31.54			X	X	--
20 x 58	20 x 56	35.3	7.42	12.04	33.18	12.57	34.22			X	X	--
20 x 61	20 x 59	36.2	7.85	12.57	34.64	13.09	35.68			X	X	--
20 x 64	20 x 62	37.1	8.29	13.09	36.10	13.61	37.14			X	X	--
20 x 67	20 x 65	37.9	8.73	13.61	37.56	14.14	46.73			X	X	--
20 x 70	20 x 69	38.7	9.16	14.14	47.15	14.66	48.50			X	X	--
20 x 73	20 x 72	39.4	9.60	14.66	48.91					X	--	--
20 x 77	20 x 75	40.2	10.04	15.18	50.68	15.71	52.02			X	X	--
20 x 80	20 x 78	40.9	10.47	15.71	52.44					X	--	--
22 x 35	22 x 32	28.7	4.56	8.38	19.68					X	--	--
22 x 38	22 x 35	30.0	5.04	8.90	20.93					X	--	--
22 x 41	22 x 38	31.3	5.52	9.43	22.18					X	--	--
22 x 44	22 x 41	32.5	6.00	9.95	23.43					X	--	--
22 x 47	22 x 45	33.7	6.48	10.47	27.70					X	--	--
22 x 50	22 x 48	34.8	6.96	11.00	29.10					X	--	--
22 x 53	22 x 51	35.8	7.44	11.52	30.51					X	--	--
22 x 57	22 x 54	36.8	7.92	12.04	33.18					X	--	--
22 x 60	22 x 58	37.8	8.40	12.57	34.64					X	--	--
22 x 63	22 x 61	38.7	8.88	13.09	36.10					X	--	--
22 x 66	22 x 64	39.6	9.36	13.61	37.56					X	--	--
22 x 69	22 x 67	40.4	9.84	14.14	39.02					X	--	--
22 x 72	22 x 70	41.3	10.32	14.66	48.92					X	--	--
22 x 75	22 x 74	42.1	10.80	15.19	50.68					X	--	--
22 x 79	22 x 77	42.8	11.28	15.71	52.44					--	--	--

NOTES:

1. Equivalent rectangular size shown for a given flat oval size is the size of a rectangular duct that has the same friction loss per unit length as the flat oval.
2. Weights are based on the outershell gauge given in Table 8 and the inner shell gauge given in Table 11
3. * = 6-foot standard length

EASY BEND ELBOWS

GORED ELBOW EASY BEND

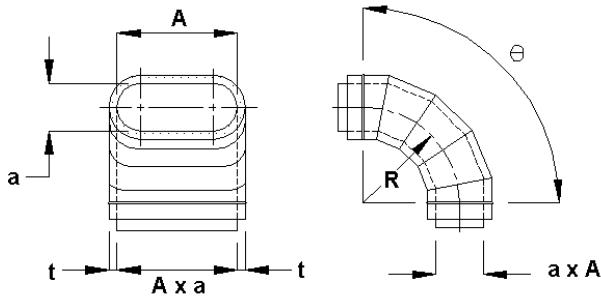

$a \leq 22$ -inches

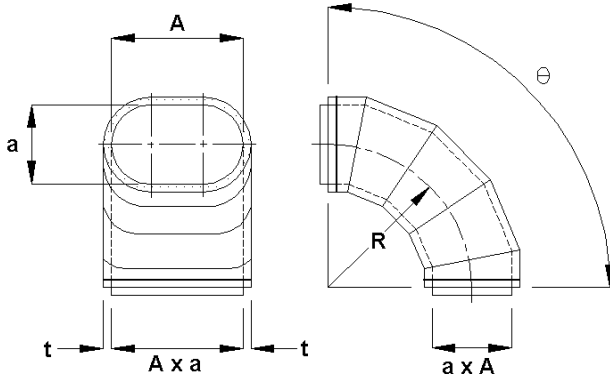

$a > 22$ -inches

DESIGNATION:
KO(*)EE#-θ

Where:

θ	Number of gores
0 - 35°	2
36 - 71°	3
72 - 90°	5

For elbows where θ exceeds 90°, add one gore for each additional 18° or fraction thereof.

DIMENSIONS:

$$R = 1.5(a+2t)$$

GORED ELBOW EASY BEND

(With Van Stone connector ends)

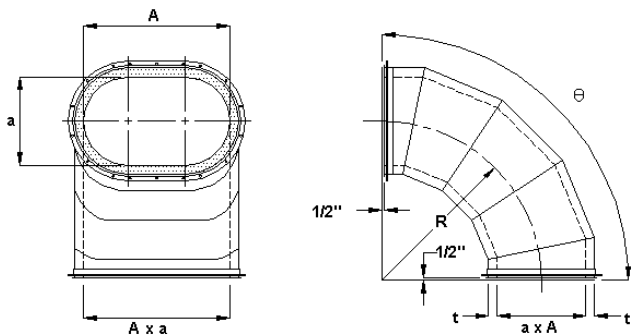

$a > 22$ -inches

Note: End gores are turned up and out 1/2 inch to create the Van Stone connector flange. For major axis outer shell dimensions that are 22 inches in diameter or smaller, see the angle ring/Van Stone connector detail on page 46.

DIMENSIONS:

$$R = 1.5(a+2t)$$

HARD BEND ELBOWS

GORED ELBOW HARD BEND

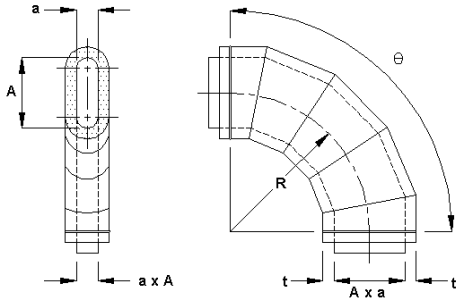

$A \leq 22$ inches

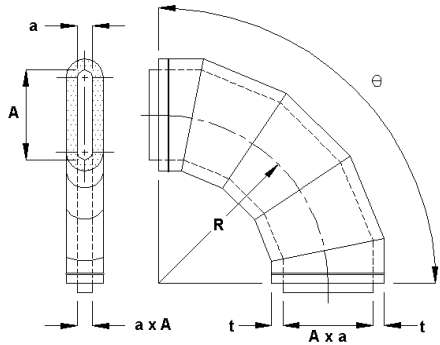

$A > 22$ inches

Designation:
KO(*)EH#-θ

Where:

θ	Number of gores
0 - 35°	2
36 - 71°	3
72 - 90°	5

For elbows where θ exceeds 90°, add one gore for each additional 18° or fraction thereof.

DIMENSIONS:
 $R = 1.5(A+2t)$

GORED ELBOW HARD BEND

(With Van Stone connector ends)

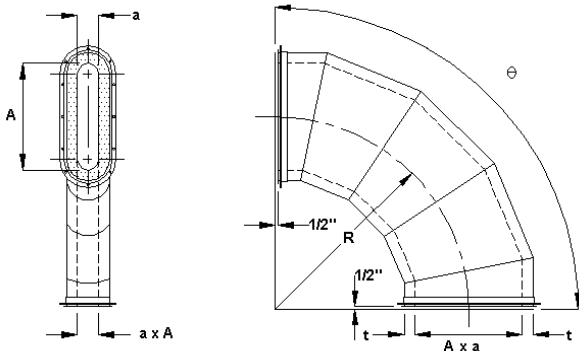

$A > 22$ inches

Note: End gores are turned up and out 1/2 inch to create the Van Stone connector flange. For major axis outer shell dimensions that are 22 inches or smaller. See the angle ring/Van Stone connector detail on page 46.

DIMENSIONS:
 $R = 1.5(A+2t)$

MITERED ELBOWS

MITERED 90° ELBOW EASY BEND

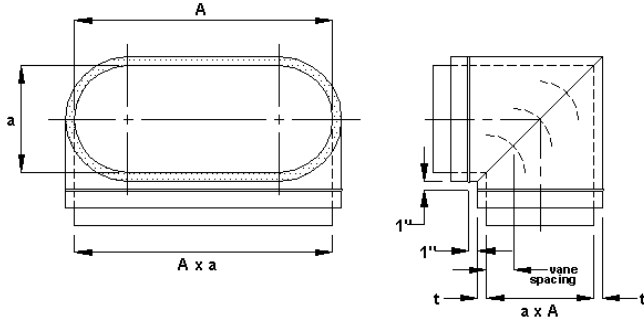

DESIGNATION:

KO(*)EMVE-90

with turning vanes
(shown)

KO(*)EME-90

without turning vanes
(not shown)

DIMENSIONS:

a (inches)	Number of Vanes
3 - 9 ½	2
10 - 14 ½	3
15 - 19	4
20 - 60	5
over 60	12-inch maximum spacing

Note: Mitered 45° elbows (two gores) are also available. Designation is KO(*)EME-45.

MITERED 90° ELBOW HARD BEND

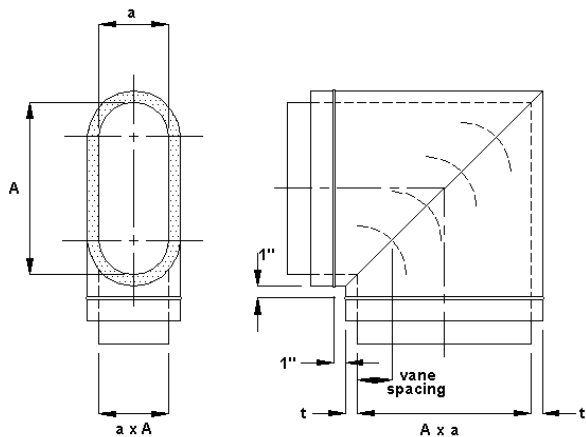

DESIGNATION:

KO(*)EMVH-90

with turning vanes
(shown)

KO(*)EMH-90

without turning vanes
(not shown)

DIMENSIONS:

A (inches)	Number of Vanes
3 - 9 ½	2
10 - 14 ½	3
15 - 19	4
20 - 60	5
over 60	12-inch maximum spacing

Note: Mitered 45° elbows (two gores) are also available. Designation is KO(*)EMH-45.

EASY BEND HEEL-TAPPED ELBOWS

HEEL-TAPPED 90° ELBOW EASY BEND

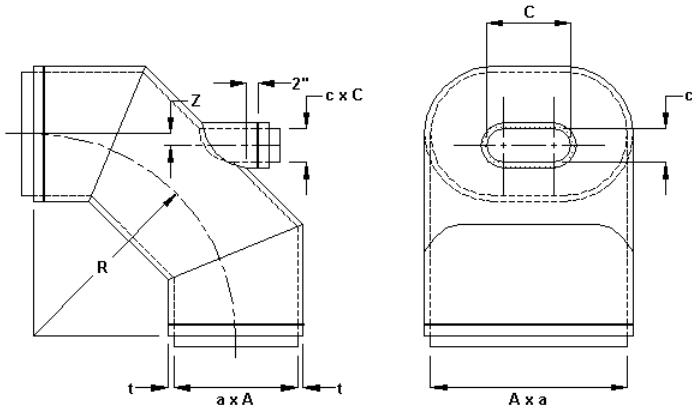

DESIGNATION:
KO(*)ETE3-90

DIMENSIONS:
 $R = 1.5a$
 $Z = 0.086a$

Maximum $c = a$
Maximum $C = A$

Tap may be round ($C = c$)

HEEL-TAPPED 45° ELBOW EASY BEND

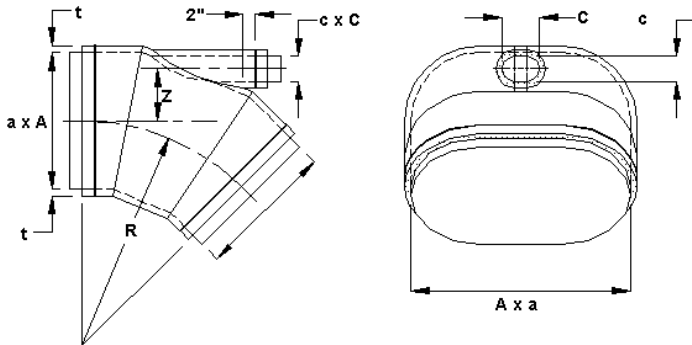

DESIGNATION:
KO(*)ETE3-45

DIMENSIONS:
 $R = 1.5a$
 $Z = 0.348a$

Maximum $c = 0.3a$
Maximum $C = A$

Tap may be round ($C = c$)

HARD BEND HEEL-TAPPED ELBOWS

HEEL-TAPPED 90° ELBOW HARD BEND

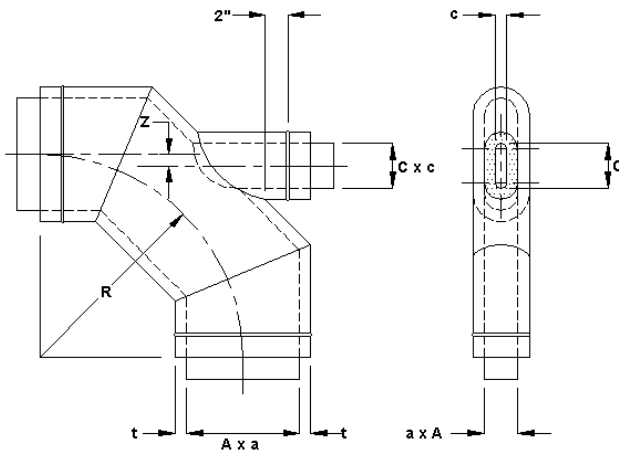

Tap may be round ($c = C$)

DESIGNATION:
KO(*)ETH3-90

DIMENSIONS:

$$R = 1.5A$$
$$Z = 0.086A$$

Maximum $C = A$
Maximum $c = a$

HEEL-TAPPED 45° ELBOW HARD BEND

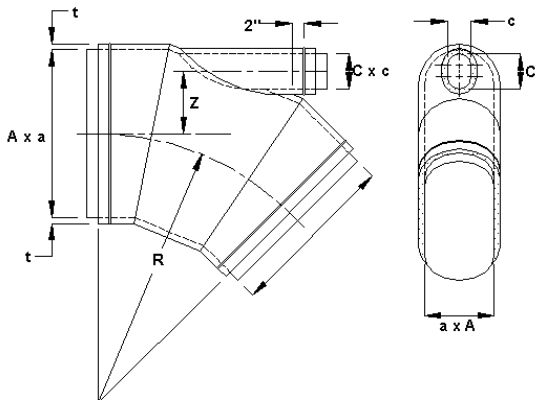

Tap may be round ($c = C$)

DESIGNATION:
KO(*)ETH3-45

DIMENSIONS:

$$R = 1.5A$$
$$Z = 0.348A$$

Maximum $C = 0.3A$
Maximum $c = a$

STRAIGHT TEE

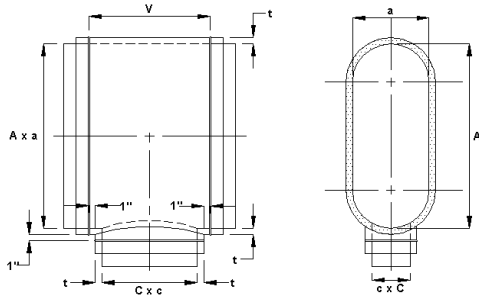

DESIGNATION:
KO(*)T

DIMENSIONS:
 $V = C + 2t + 2$
 Maximum $C = A$
 Maximum $c = a$

CONICAL TEE

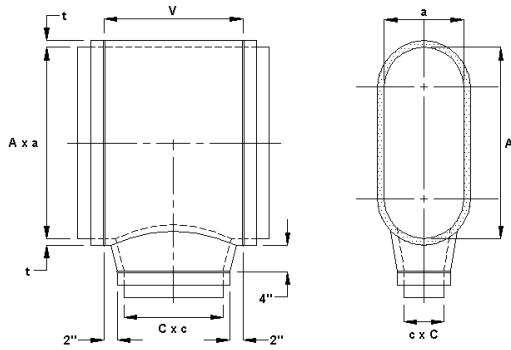

DESIGNATION:
KO(*)TC

DIMENSIONS:
 $V = C + 2t + 4$
 Maximum $C = A - 2$
 Maximum $c = a - 2$

LO-LOSS TEE

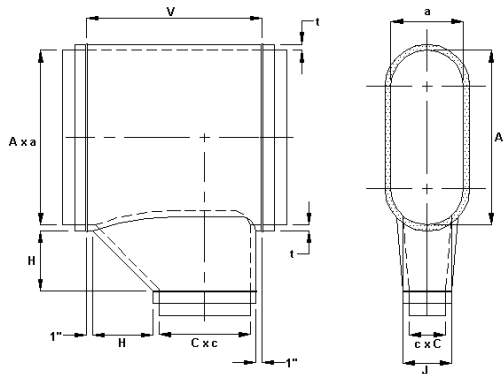

DESIGNATION:
KO(*)TL

DIMENSIONS:
 $V = C + H + 2t + 2$
 $J = c + 2$ (for $c \leq a - 2$)
 $J = c$ (for $c > a - 2$)
 Maximum $C = A$
 Maximum $c = a$

C (inches)	H (inches)
3 - 8	4
8 ½ - 14	7
14 ½ - 26	10
27 or larger	13

STRAIGHT LATERAL

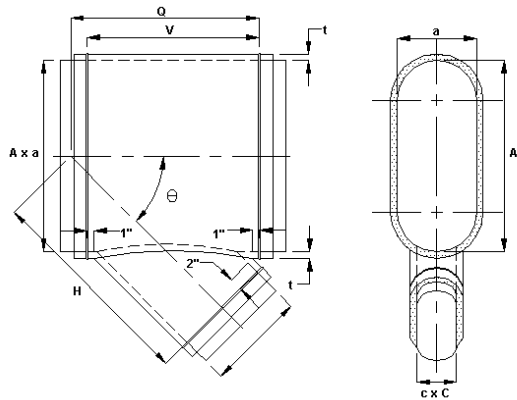

DESIGNATION:

KO(*)L
(-θ if θ ≠ 45°)

DIMENSIONS:

$$V = \frac{C + 2t}{\sin \theta} + 2$$

$$Q = \frac{A + 2t}{2 \tan \theta} + \frac{C + 2t}{2 \sin \theta} + 1$$

$$H = \frac{A + 2t}{2 \sin \theta} + \frac{C + 2t}{2 \tan \theta} + 2$$

Maximum C = A and c = a

CONICAL LATERAL

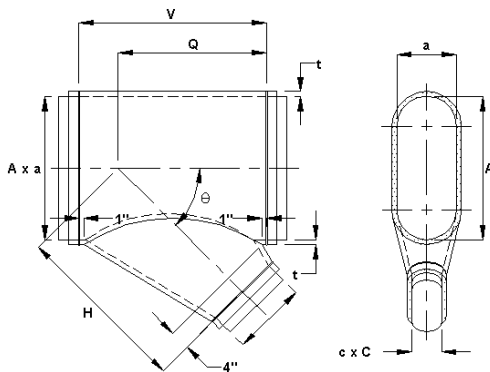

DESIGNATION:

KO(*)LC
(-θ if θ ≠ 45°)
(for θ ≥ 30°)

DIMENSIONS:

$$V = \frac{(C + 2t + 2)}{\sin \theta} + 2$$

$$Q = \frac{A + 2t}{2 \tan \theta} + \frac{C + 2\alpha + 2t}{2 \sin \theta} + 1$$

$$H = \frac{A + 2t}{2 \sin \theta} + \frac{C + 2\alpha + 2t}{2 \tan \theta} + 4$$

$$\alpha = \frac{2}{\frac{(C + 2t + 2)}{\sin \theta} + 2} + 2$$

Maximum C = A - 3 for A ≤ 10
A - 4 for 10 < A ≤ 42
A - 5 for A > 42

Maximum c = a - 2

STRAIGHT 90° CROSS

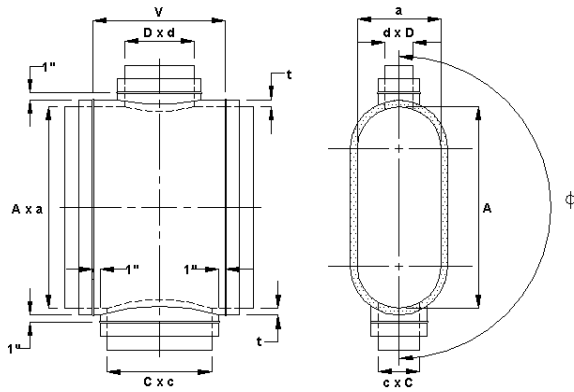

DESIGNATION: KO(*)TX
(-phi if phi ≠ 180°)

DIMENSIONS:
 $V = C + 2t + 2$

Maximum C or D = A
Maximum c or d = a

Either tap may be round ($c = C$ or $d = D$)

CONICAL 90° CROSS

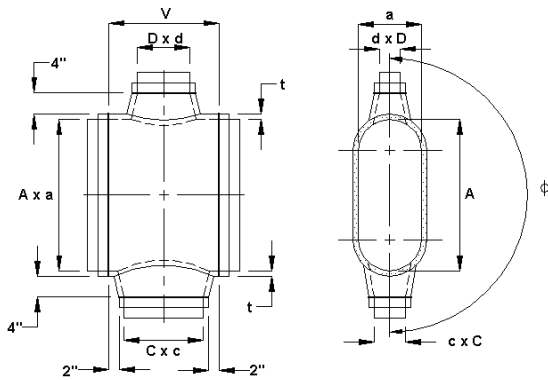

DESIGNATION:
KO(*)TXC
(-phi if phi ≠ 180°)

DIMENSIONS:
 $V = C + 2t + 4$

Maximum C or D = A - 2
Maximum c or d = a - 2

Either tap may be round ($c = C$ or $d = D$)

LO-LOSS 90° CROSS

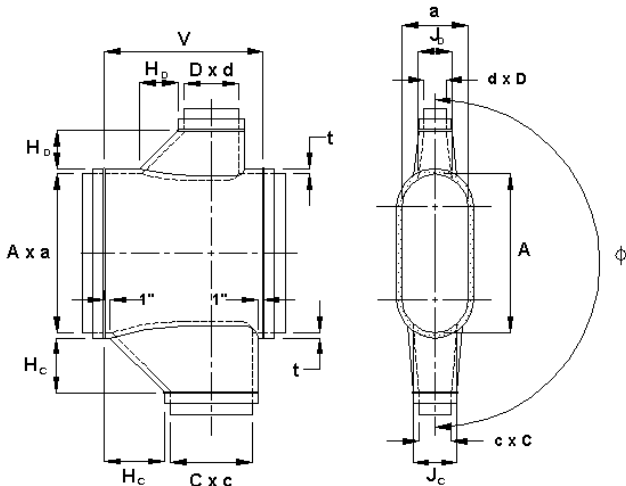

DESIGNATION:
KO(*)TXL
(-phi if phi ≠ 180°)

DIMENSIONS:
 $V = C + H_C + 2t + 2$

Note: To determine $J_C + J_D$ dimension and maximum C, D, c, or d, refer to the LO-LOSS tee drawing.

C or D (inches)	H _C or H _D (inches)
3 - 8	4
9 - 14	7
15 - 26	10
27 or larger	13

LATERAL CROSS

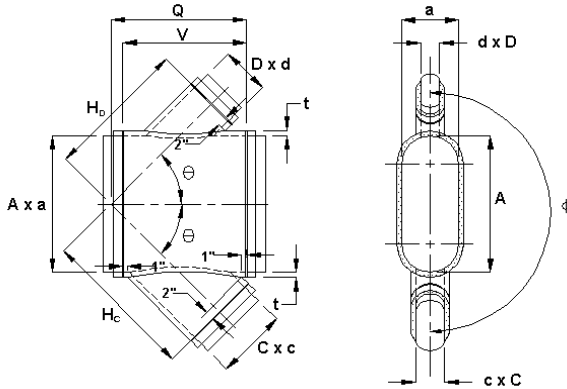

DESIGNATION:

KO(*)LX

(-θ if θ ≠ 45°)

(-φ if φ ≠ 180°)

DIMENSIONS:

$$V = \frac{C + 2t}{\sin \theta} + 2$$

$$Q = \frac{A + 2t}{2 \tan \theta} + \frac{C + 2t}{2 \sin \theta} + 1$$

$$H_c = \frac{A + 2t}{2 \sin \theta} + \frac{C + 2t}{2 \tan \theta} + 2$$

$$H_d = \frac{A + 2t}{2 \sin \theta} + \frac{D + 2t}{2 \tan \theta} + 2$$

Either tap may be round (c = C or d = D)

Maximum C or D = A

Maximum c or d = a

END CAP

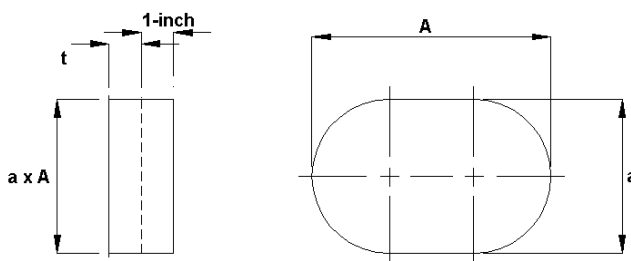

DESIGNATION:

KO(*)EC (for duct)

KO(*)ECF (for fittings)

Y-BRANCH, HARD BEND

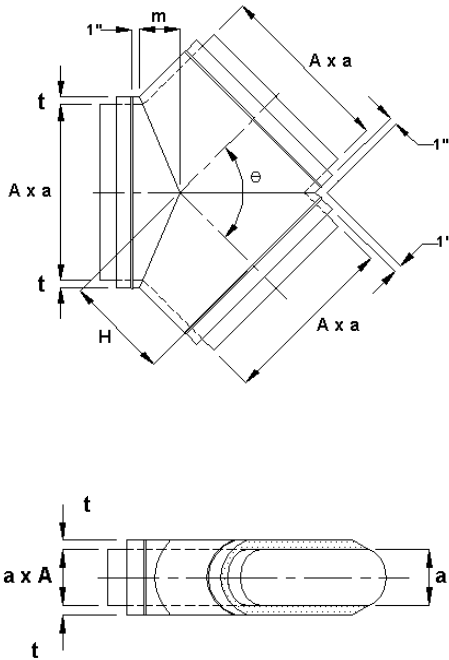

DESIGNATION:
KO(*)YH
(-θ if θ ≠ 90°)

DIMENSIONS:

$$H = \frac{A + 2t}{2 \tan(\theta / 2)} + 1$$

$$m = \left(\frac{A + 2t}{2} \right) \tan(\theta / 4)$$

Y-BRANCH, EASY BEND

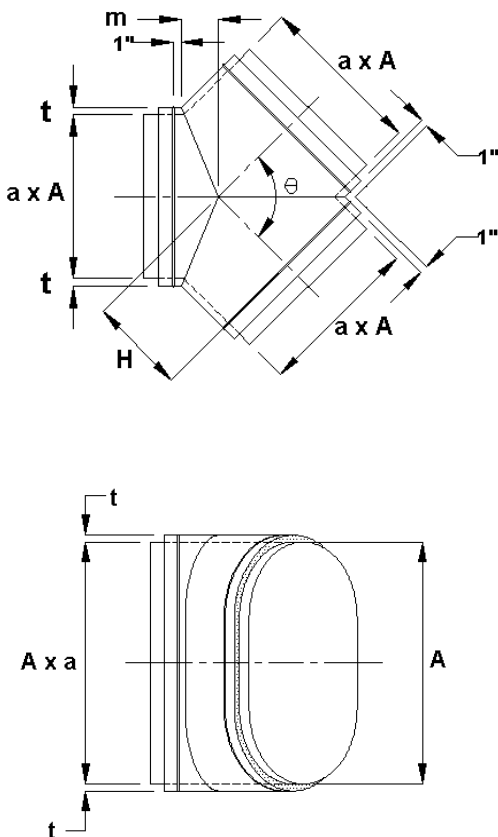

DESIGNATION:
KO(*)YE
(-θ if θ ≠ 90°)

DIMENSIONS:

$$H = \frac{a + 2t}{2 \tan(\theta / 2)} + 1$$

$$m = \left(\frac{a + 2t}{2} \right) \tan(\theta / 4)$$

BULLHEAD TEE, HARD BEND

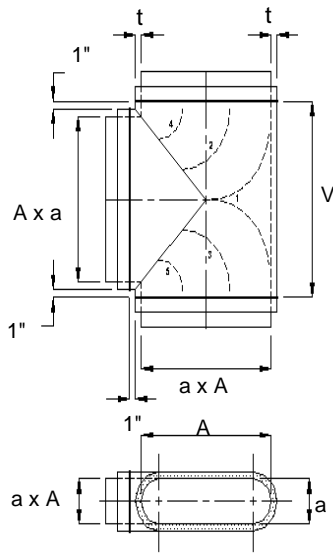

DESIGNATION:

KO(*)TBVH

with turning vanes
shown)

KO(*)TBH

without turning vanes
not shown)

DIMENSIONS:

$$V = A + 2t + 2$$

A (inches)	Number of Vanes
7 - 9	3
10 - 60	5
over 60	12-inch maximum spacing

BULLHEAD TEE, EASY BEND

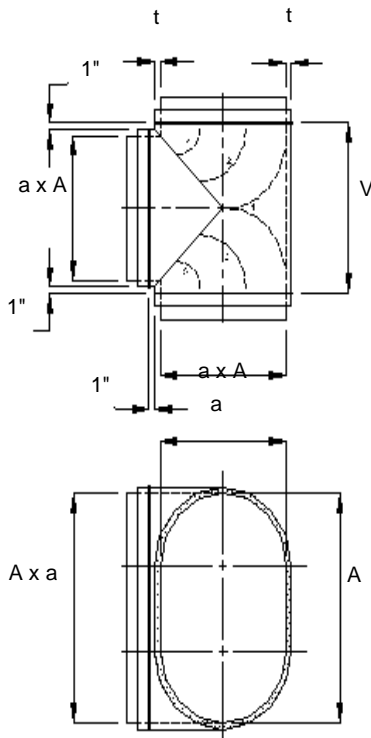

DESIGNATION:

KO(*)TBVE

with turning vanes
(shown)

KO(*)TBE

with turning vanes
(shown)

DIMENSIONS:

$$V = a + 2t + 2$$

a (inches)	Number of Vanes
3 - 6	1
7 - 9	3
10 - 60	5
over 60	12-inch maximum spacing

CONTOURED FLANGED STRAIGHT TEE TAP

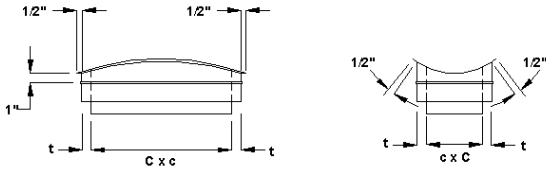

DESIGNATION:
KO(*)PT

DIMENSIONS:
Specify duct size to which tap will be attached as a x A (if round body, specify A only).

Maximum C = A
Maximum c = a

SADDLED STRAIGHT TEE TAP

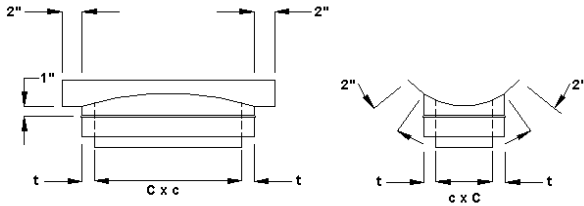

DESIGNATION:
KO(*)PTS

DIMENSIONS:
Specify duct size to which tap will be attached as a x A (if round body, specify A only).

Maximum C = A
Maximum c = a

CONTOURED FLANGED CONICAL TEE TAP

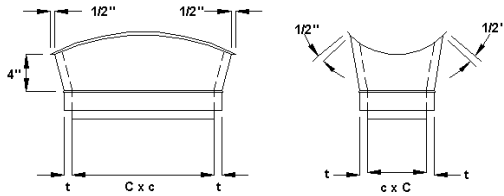

DESIGNATION:
KO(*)PTC

DIMENSIONS:
Specify duct size to which tap will be attached as a x A (if round body, specify A only).

Maximum C = A - 2
Maximum c = a - 2

SADDLE CONICAL TEE TAP

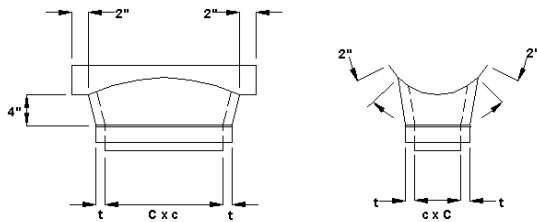

DESIGNATION:
KO(*)PTCS

DIMENSIONS:
Specify duct size to which tap will be attached as a x A (if round body, specify A only).

Maximum C = A - 2
Maximum c = a - 2

CONTOURED FLANGED LO-LOSS TEE TAP

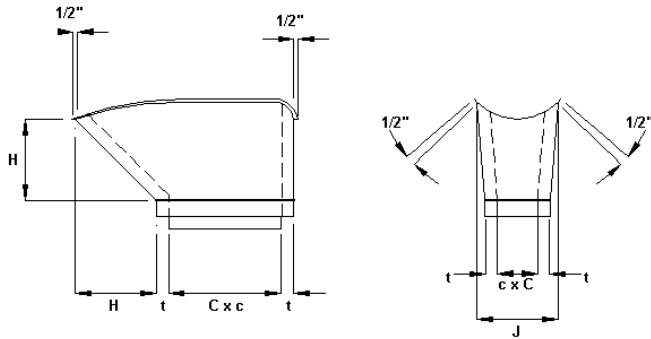

DESIGNATION:
KO(*)PTL

DIMENSIONS:
Specify duct size to which tap will be attached as a x A (if round body, specify A only).

$$J = c + 2 \quad (\text{for } c \leq a - 2)$$

$$J = c \quad (\text{for } c > a - 2)$$

Maximum C = A
Maximum c = a

C (inches)	H (inches)
3 - 8	4
9 - 14	7
15 - 26	10
27 or larger	13

SADDLE LO-LOSS TEE TAP

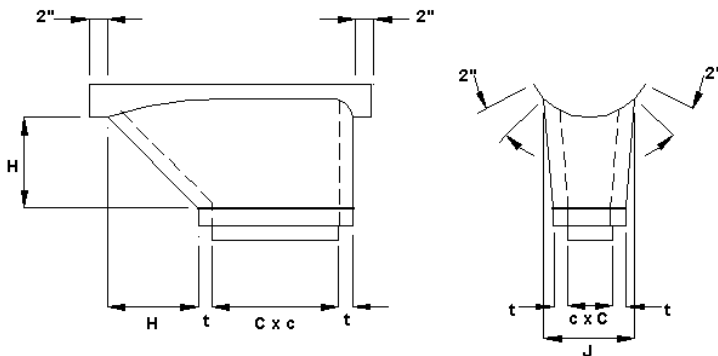

DESIGNATION:
KO(*)PTLS

DIMENSIONS:
Specify duct size to which tap will be attached as a x A (if round body, specify A only).

$$J = c + 2 \quad (\text{for } c \leq a - 2)$$

$$J = c \quad (\text{for } c > a - 2)$$

Maximum C = A
Maximum c = a

C (inches)	H (inches)
3 - 8	4
9 - 14	7
15 - 26	10
27 or larger	13

CONTOURED FLANGED LATERAL TAP

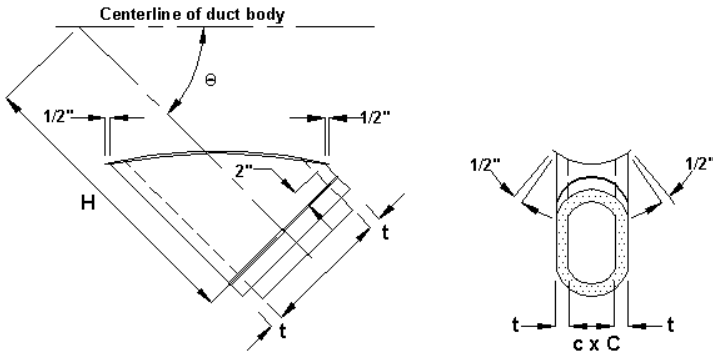

DESIGNATION:
KO(*)PL

DIMENSIONS:

Specify duct size to which tap will be attached as a x A (if round body, specify A only).

Maximum C = A
Maximum c = a

$$H = \frac{A + 2t}{2\sin\theta} + \frac{C + 2t}{2\tan\theta} + 2$$

SADDLE LATERAL TAP

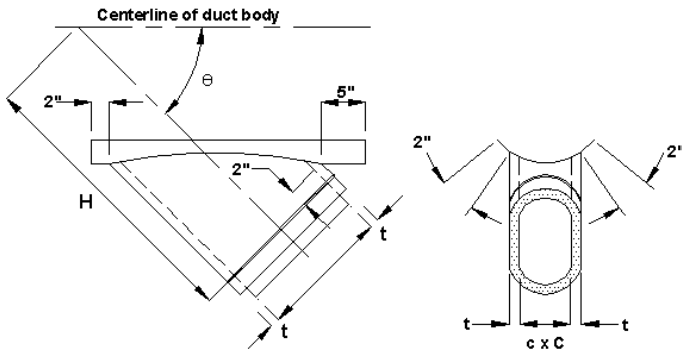

DESIGNATION:
KO(*)PLS
(-theta if theta ≠ 45°)

DIMENSIONS:

Specify duct size to which tap will be attached as a x A (if round body, specify A only).

Maximum C = A
Maximum c = a

$$H = \frac{A + 2t}{2\sin\theta} + \frac{C + 2t}{2\tan\theta} + 2$$

CONTOURED FLANGED CONICAL LATERAL TAP

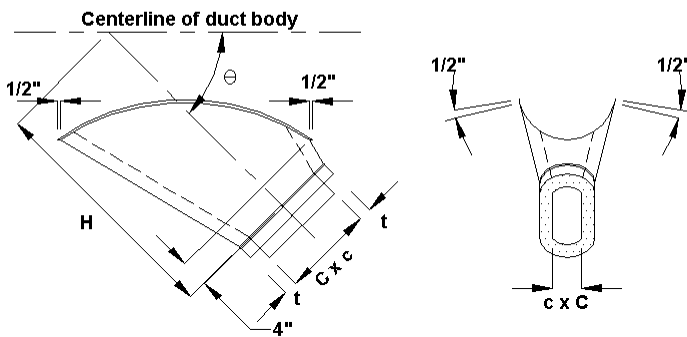

DESIGNATION:

KO(*)PLC

(-θ if θ ≠ 45°)

(for θ ≥ 30°)

DIMENSIONS:

Specify duct size to which tap will be attached as a x A (if round body, specify A only).

Maximum C = A - 3 for A ≤ 10
 A - 4 for 10 < A ≤ 42
 A - 5 for A > 42

Maximum c = a - 2

$$H = \frac{A + 2t}{2\sin\theta} + \frac{C + 2\alpha + 2t}{\tan\theta} + 4$$

$$\alpha = \frac{2}{\frac{(C + 2t + 2)}{4\tan\theta} + 2}$$

SADDLE CONICAL LATERAL TAP

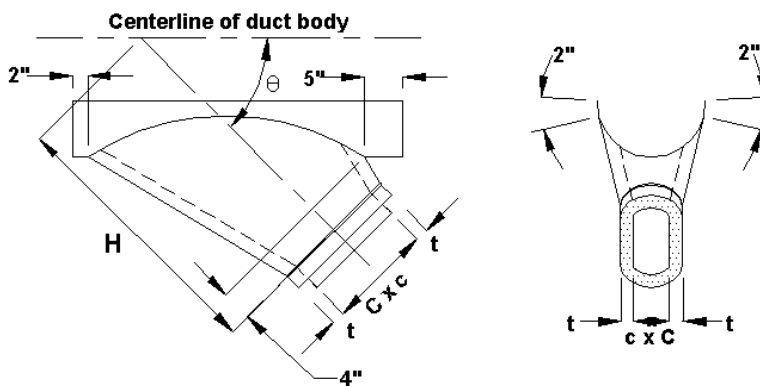

DESIGNATION:

KO(*)PLCS

(-θ if θ ≠ 45°)

(for θ ≥ 30°)

DIMENSIONS:

Specify duct size to which tap will be attached as a x A (if round body, specify a only).

Maximum C = A - 3 for A ≤ 10
 A - 4 for 10 < A ≤ 42
 A - 5 for A > 42

Maximum c = a - 2

$$H = \frac{A + 2t}{2\sin\theta} + \frac{C + 2\alpha + 2t}{\tan\theta} + 4$$

$$\alpha = \frac{2}{\frac{(C + 2t + 2)}{4\tan\theta} + 2}$$

RECTANGULAR TAP

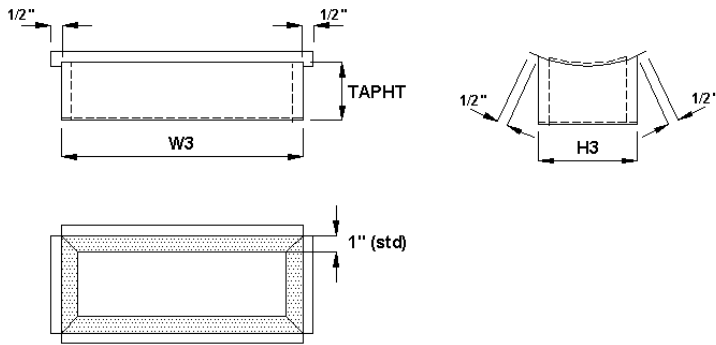

DESIGNATION:

KO(*)PTA

(Flange-in shown on outer shell)

DIMENSIONS:

Specify tap size ($W3 \times H3$) and duct size ($a \times A$) that tap will be attached to and indicate end detail, i.e., flange-in, flange-out, or raw. Provide sketch of orientation if different than noted.

Default: TAPHT = 3 inches

RECTANGULAR LO-LOSS TAP

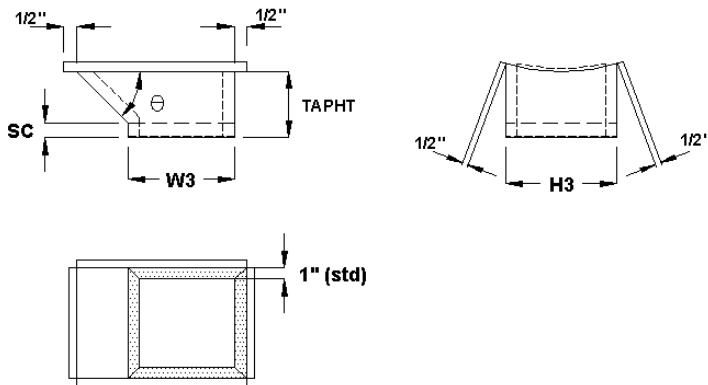

DESIGNATION:

KO(*)PTLA

(Flange-in shown on outer shell)

DIMENSIONS:

Specify tap size ($W3 \times H3$) and duct size ($a \times A$) that tap will be attached to and indicate end detail, i.e., flange-in, flange-out or raw. Provide sketch of orientation if different than noted.

Default: TAPHT = 6 inches

SC = 2 inches

$\theta = 45^\circ$

OFFSET, HARD BEND

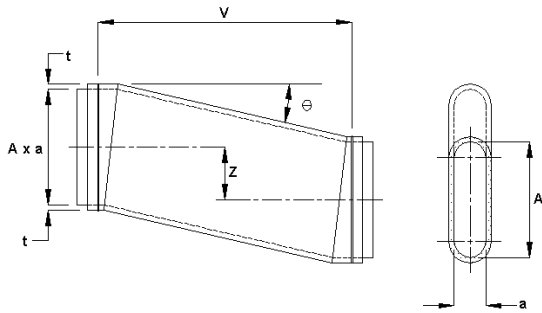

DESIGNATION:
KO(*)ZH

DIMENSIONS:

$$V = 2A + 4t$$

Z = Must be specified

Note: Z should not exceed 0.75A or $\theta > 60^\circ$. If larger, use fabricated elbows and a straight length of duct.

OFFSET, EASY BEND

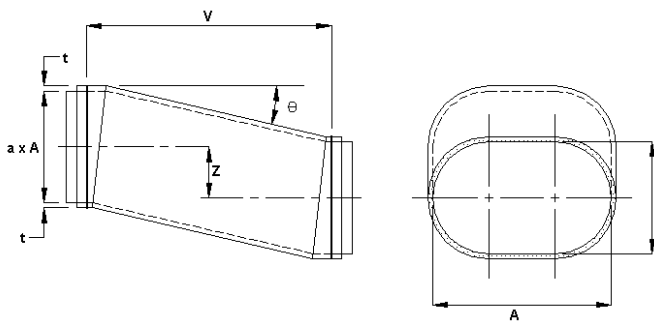

DESIGNATION:
KO(*)ZE

DIMENSIONS:

$$V = 2a + 4t$$

Z = Must be specified

Note: Z should not exceed 0.75a or $\theta > 60^\circ$. If larger, use fabricated elbows and a straight length of duct.

SQUARE-TO-FLAT OVAL

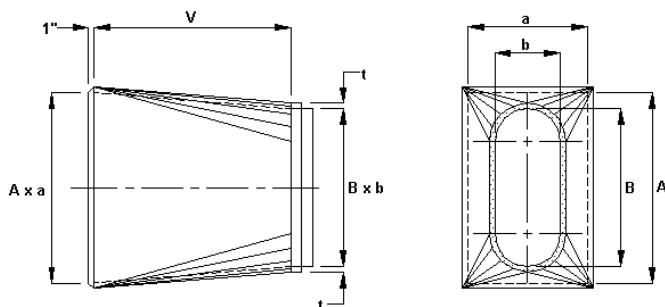

DESIGNATION:
KO(*)QR

DIMENSIONS:

$$V = 12, 24, 36, \text{ or } 48 \text{ inches}$$

A = Major axis of rectangular side

a = Minor axis of rectangular side

CONCENTRIC TRANSITION

(Round-to-flat oval)

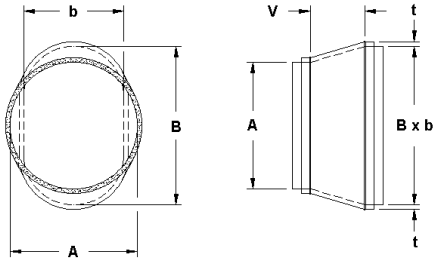

DESIGNATION:

KO(*)R-10

DIMENSIONS:

$V = 12$ if greater of $(B-A)$ or $(b-a) \leq 16$

$V = 24$ if greater of $(B-A)$ or $(b-a) > 16$

ECCENTRIC TRANSITION

(Round-to-flat oval: minor axis tangent to round)

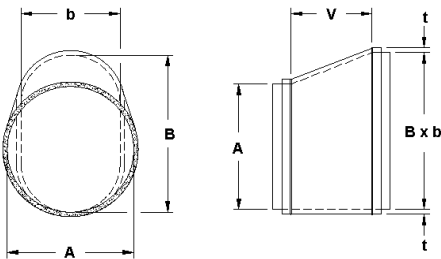

DESIGNATION:

KO(*)R-11

DIMENSIONS:

$V = 18$ if greater of $(B-A)$ or $(b-a) \leq 24$

$V = 36$ if greater of $(B-A)$ or $(b-a) > 24$

ECCENTRIC TRANSITION

(Round-to-flat oval: major axis tangent to round)

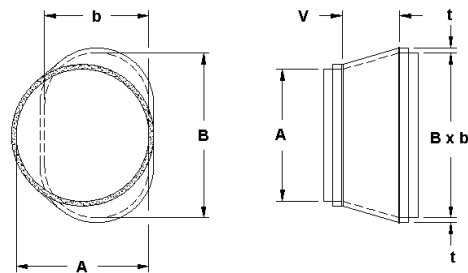

DESIGNATION:

KO(*)R-12

DIMENSIONS:

$V = 12$ if greater of $(B-A)$ or $(b-a) \leq 16$

$V = 24$ if greater of $(B-A)$ or $(b-a) > 16$

ECCENTRIC TRANSITION

(Round-to-flat oval: two adjacent sides tangent)

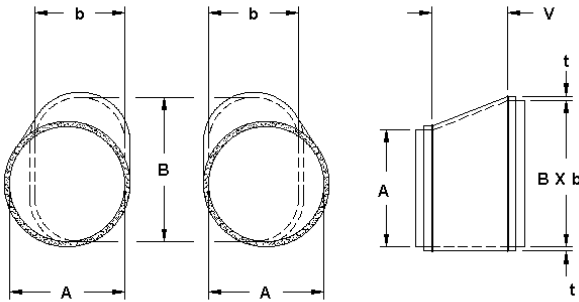

DESIGNATION:

KO(*)R-131

(ARR #1)

KO(*)R-132

(ARR #2)

DIMENSIONS:

$V = 18$ if greater of $(B-A)$ or $(b-a) \leq 24$

$V = 36$ if greater of $(B-A)$ or $(b-a) > 24$

CONCENTRIC TRANSITION

(Flat oval-to-flat oval: parallel axis)

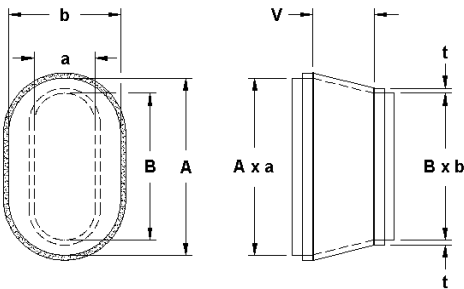

DESIGNATION:

KO(*)R-30

DIMENSIONS:

$V = 12$ if greater of $(A-B)$ or $(a-b) \leq 16$

$V = 24$ if greater of $(A-B)$ or $(a-b) > 16$

ECCENTRIC TRANSITION

(Flat oval-to-flat oval: parallel axis, minor axis sides tangent)

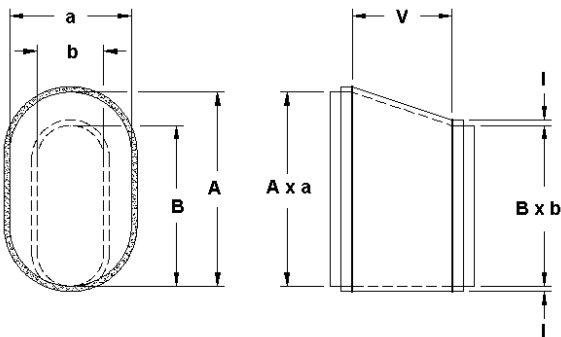

DESIGNATION:

KO(*)R-31

DIMENSIONS:

$V = 18$ if greater of $(A-B)$ or $(a-b) \leq 24$

$V = 36$ if greater of $(A-B)$ or $(a-b) > 24$

ECCENTRIC TRANSITION

(Flat oval-to-flat oval: parallel axis, major axis sides tangent)

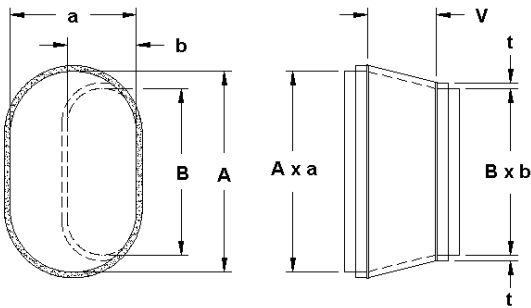

DESIGNATION:
KO(*)R-32

DIMENSIONS:
V=12 if greater of
(A-B) or (a-b) \leq 16

V = 24 if greater of
(A-B) or (a-b) > 16

ECCENTRIC TRANSITION

(Flat oval-to-flat oval: parallel axis, two adjacent sides tangent)

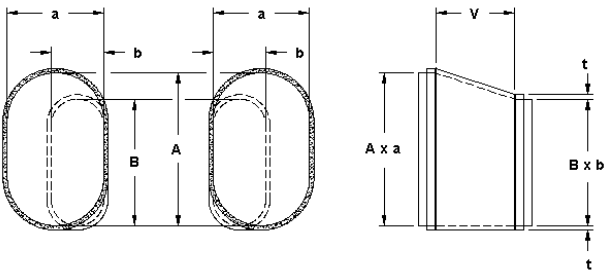

DESIGNATION:
KO(*)R-331
(ARR #1)
KO(*)R-332
(ARR #2)

DIMENSIONS:
V = 18 if greater of
(A-B) or (a-b) \leq 24

V = 36 if greater of
(A-B) or (a-b) > 24

CONCENTRIC TRANSITION

(Flat oval-to-flat oval: rotated axis)

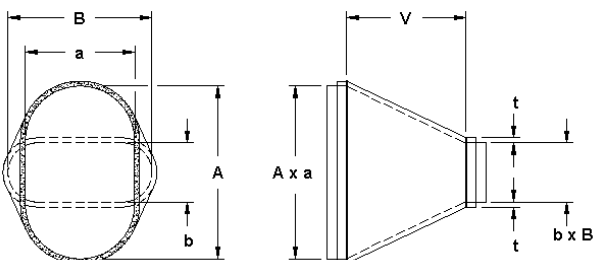

DESIGNATION:
KO(*)R-40

DIMENSIONS:
V = 12 if greater of
(A-b) or (a-B) \leq 16

V = 24 if greater of
(A-b) or (a-B) > 16

ECCENTRIC TRANSITION

(Flat oval-to-flat oval: rotated axis, tangent to air entering side minor axis)

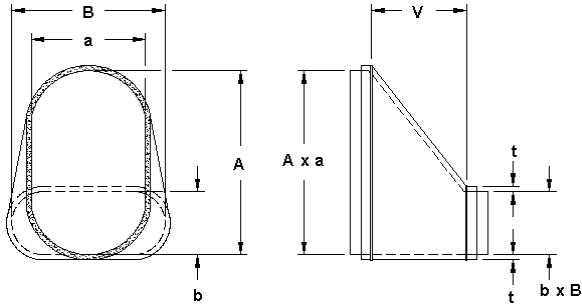

DESIGNATION:
KO(*)R-41

DIMENSIONS:
V = 18 if greater of
(A-b) or (a-B) ≤ 24

V = 36 if greater of
(A-b) or (a-B) > 24

ECCENTRIC TRANSITION

(Flat oval-to-flat oval: rotated axis, tangent to air entering side major axis)

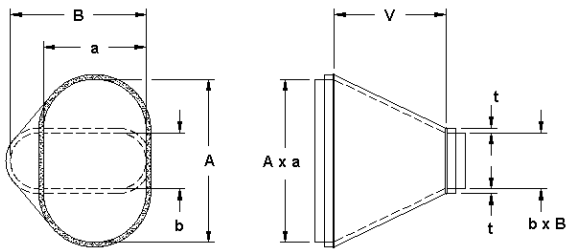

DESIGNATION:
KO(*)R-42

DIMENSIONS:
V = 12 if greater of
(A-b) or (a-B) ≤ 16

V = 24 if greater of
(A-b) or (a-B) > 16

ECCENTRIC TRANSITION

(Flat oval-to-flat oval: rotated axis, two adjacent sides tangent)

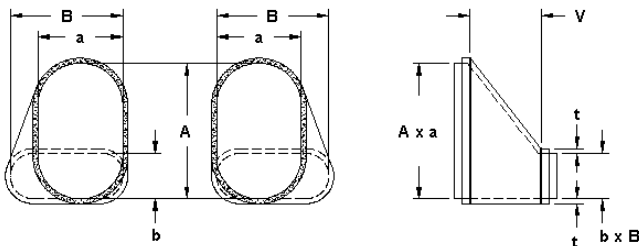

DESIGNATION:
KO(*)R-431
(ARR #1)
KO(*)R-432
(ARR #2)

DIMENSIONS:
V = 18 if greater of
(A-b) or (a-B) ≤ 24

V = 36 if greater of
(A-b) or (a-B) > 24

DUCT-TO-DUCT COUPLING

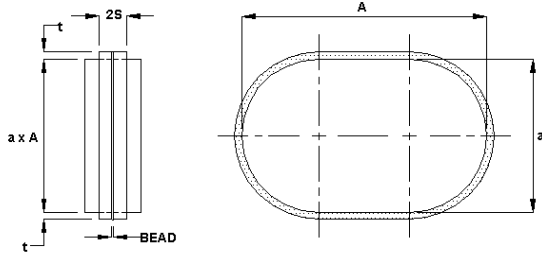

DESIGNATION:
KO(*)C

DIMENSIONS:

a + 2t (inches)	Bead (inches)
7 - 23 over 23	1/4 5/8

FITTING-TO-FITTING COUPLING

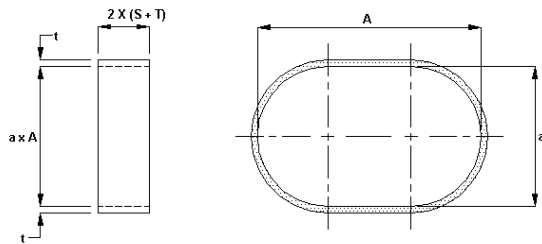

DESIGNATION:
KO(*)CF

SINGLE-WALL INSULATION END

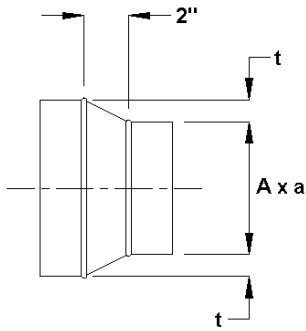

DESIGNATION:

SOSIE(DD, DF, FD, or FF)-#

Where:

DD = double-wall duct to single-wall duct
 DF = double-wall duct to single-wall fitting
 FD = double-wall fitting to single-wall duct
 FF = double-wall fitting to single-wall fitting

Explanation:

- 1 = Loose insulation end
- 2 = Insulation end is tack welded and bonded to double-wall duct or fitting
- 3 = Insulation end is solid welded to outer wall of double-wall duct or fitting

Example designation:

SOSIEDD-1

SINGLE-WALL INSULATION END

(With inner collar)

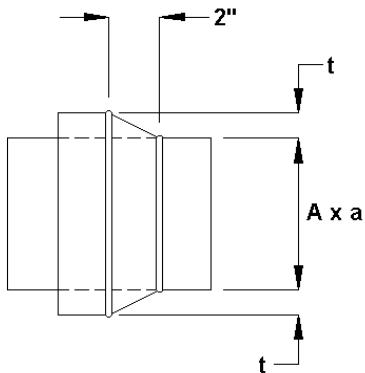

DESIGNATION:

SOSIE(DD, DF, FD, or FF)-4

Where:

DD = double-wall duct to single-wall duct
 DF = double-wall duct to single-wall fitting
 FD = double-wall fitting to single-wall duct
 FF = double-wall fitting to single-wall fitting

Example designation:

SOSIEDD-4

APPLIED DUCT CONNECTOR

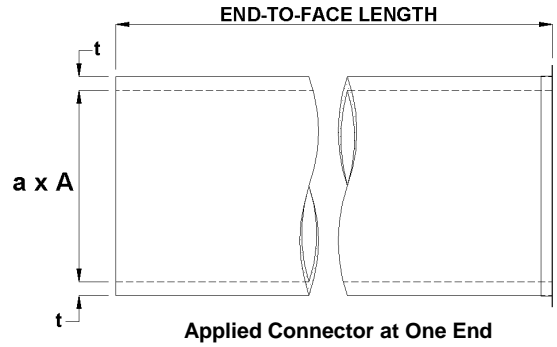
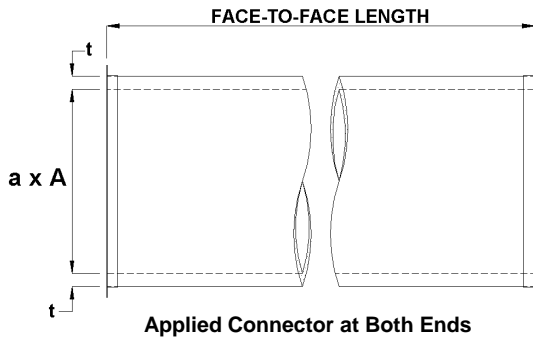

Note: Customer-specified duct length shall be the face-to-face or end-to-face dimension. Standard coil widths are 60 and 72-inch. When either of these lengths are requested on longitudinal seam duct with an angle ring, the ring is pulled $\frac{1}{2}$ inch for welding, and the overall length will finish $\frac{1}{2}$ inch longer. For example, a 60-inch length of longitudinal seam duct will finish 61-inches if iron angle rings are welded onto both ends. On all other applied connectors, the overall length does not change.

APPLIED AND VAN STONE FITTINGS CONNECTORS

Type of Connector	a (inches)	S (inches)
Van Stone	5 - 9	1 $\frac{1}{2}$
Van Stone	9 $\frac{1}{2}$ - 72	3 $\frac{1}{2}$
Applied	5 - 72	2 $\frac{1}{4}$

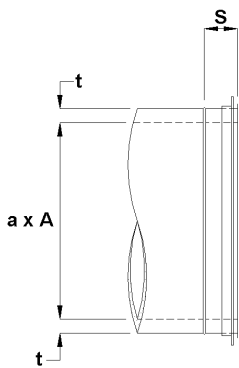

Van Stone Connector on Fitting End

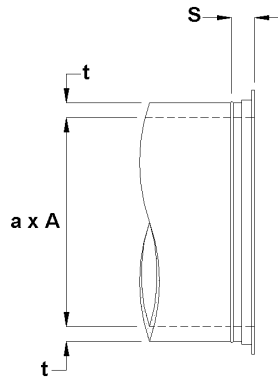

Applied Connector on Fitting End

Notes:

1. Customer to specify face-to-face dimensions for nonstandard fittings construction (i.e., nonstandard centerline radius on elbow or tap and body extensions on divided-flow fittings).
2. The bead is shown for reference only. Fittings requiring connectors are pipe sized and do not require a bead.
3. For gored elbows, refer to pages 23 and 24 showing gored elbows.

STANDARD ASSEMBLY DRAWING

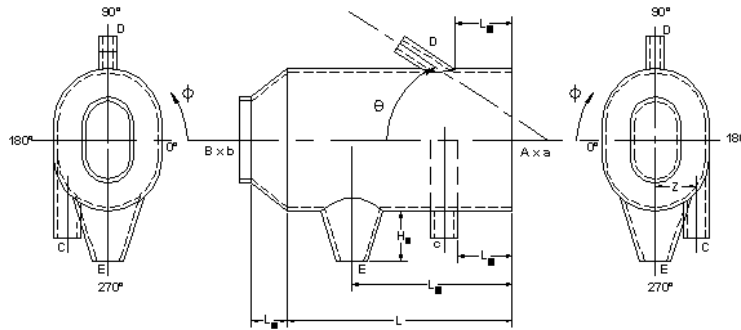

Looking through B:

- $A \times a$ = Inner dimension of large end (major x minor)
 $B \times b$ = Inner dimension of small end if reducing (major x minor)
 C = Inner dimension of first tap
 D = Inner dimension of second tap
 E = Inner dimension of third tap
 H_E = Tap height of third tap (only when nonstandard height)
 L = Length of duct
 L_C = Dimension to first tap
 L_D = Dimension to second tap
 L_E = Dimension to third tap
 L_R = Reducer length
 Z_C = Offset position of first tap
 Z_D = Offset position of second tap
 Z_E = Offset position of third tap
 θ = Location (in degrees) of lateral tap
 ϕ_C = Location (in degrees) of first tap
 ϕ_D = Location (in degrees) of second tap
 ϕ_E = Location (in degrees) of third tap

Looking through A:

- $\phi_C = 270^\circ$ $Z_C = X, -X$
 $\phi_D = 90^\circ$ $Z_D = 0$
 $\phi_E = 270^\circ$ $Z_E = 0$

Notes:

1. X = specified distance
2. The end view is located to the right of the plan view if looking through the A end.
3. The end view is located to the left of the plan view if looking through the B end.
4. All taps, except for conical taps, are measured from the right hand side to the first end of the tap. Conical taps are measured from the right hand side (e.g. L_E) from the centerline of the tap.
5. Refer to the examples at the front of this booklet for instructions about changing the orientation of the taps in relationship to the duct section (e.g., $maja$, $minx$).

ACOUSTI-k27[®], and Longitudinal Seam-k27[®] are registered trademarks, and UNI-SEAL[™], United Duct Sealer[™], LO-LOSS[™], and UNI-RING[™] are trademarks of United McGill Corporation.

The products depicted in these dimension sheets were current at the time of publication. As a quality conscious manufacturer, McGill AirFlow Corporation is constantly seeking ways to improve its products to better serve its customers. Therefore, all designs, specifications, and product features are subject to change without notice.

McGill AirFlow LLC

An enterprise of United McGill Corporation —
Founded in 1951

Corporate Headquarters

One Mission Park
Groveport, Ohio 43125-1149
614/836-9981, Fax: 614/836-9843
E-mail: marketing@mcgillairflow.com
Web site: mcgillairflow.com